

TM 11-5820-295-10

DEPARTMENT OF THE ARMY TECHNICAL MANUAL

7610 K78 4257

OPERATOR'S MANUAL
RADIO SET AN/GRC-19



HEADQUARTERS, DEPARTMENT OF THE ARMY
5 JUNE 1963

WARNING

DANGEROUS VOLTAGES EXIST IN THE FOLLOWING TRANSMITTER, RADIO T-195(*)/GRC-19 UNITS:

Modulator 1,000 volts
Power amplifier 1,000 volts

DANGEROUS VOLTAGES EXIST AT THE ANTENNA TERMINALS

Be careful when working around the antenna or the antenna terminals because high radiofrequency voltages exist at these points. Cover the WHIP ANTENNA binding post with an electrical rubber cap if the T-195(*)/GRC-19 is to be operated.

RADIATION HAZARD

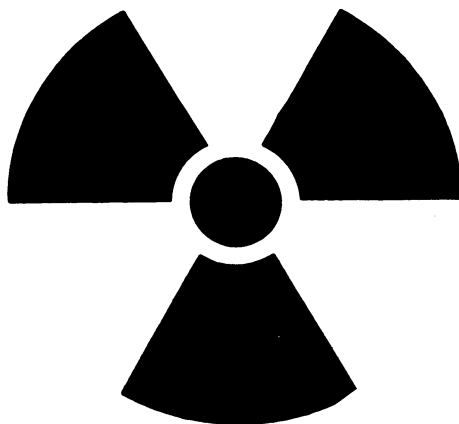

Co60
Ni63

Tube type 0A2 or 0A2WA is used in this equipment and contains radioactive material (para 44). These tubes are potentially hazardous when broken; see qualified medical personnel and the Safety Director if you are exposed to or cut by broken tubes. Use extreme care with these tubes.

Technical Manual
No. 11-5820-295-10

HEADQUARTERS,
DEPARTMENT OF THE ARMY
WASHINGTON 25, D. C., 5 June 1963

RADIO SET AN/GRC-19

			Paragraph	Page
CHAPTER	1.	INTRODUCTION		
	Section I.	General		
		Scope	1	5
		Index of publications	2	5
		Forms and records	3	5
	Section II.	Description and data		
		Purpose and use	4	5
		Technical characteristics	5	5
		Components of Radio Set AN/GRC-19	6	6
		Description of Radio Set AN/GRC-19	7	6
		Description of Transmitter, Radio T-195(*)/GRC-19	8	6
		Description of Receiver, Radio R-392/URR	9	6
		Description of Mounting MT-851/GRC-19	10	6
		Description of minor components	11	6
		System applications	12	8
CHAPTER	2.	INSTALLATION		
		General	13	11
		Removal and replacement of T-195(*)/GRC-19 and R-392/URR from MT-851/GRC-19	14	11
		Whip antenna installation	15	11
		External connections	16	11
CHAPTER	3.	OPERATING INSTRUCTIONS		
	Section I.	Operator's controls and indicators		
		Damage from improper settings	17	13
		Transmitter, Radio T-195(*)/GRC-19 controls and indicators	18	13
		Transmitter, Radio T-195(*)/GRC-19 front panel connectors	19	14
		Receiver, Radio R-392/URR, operating controls, indicators, and connectors	20	14
	Section II.	Operation		
		Types of operation	21	17
		Starting procedures for AN/GRC-19	22	17
		Operational procedures	23	19
		Recognition and identification of jamming	24	21
		Antijamming	25	21
		Stopping procedure	26	21
CHAPTER	4.	MAINTENANCE INSTRUCTIONS		
		Scope of operator's maintenance	27	23
		Preventive maintenance	28	23
		Preventive maintenance checks and services periods	29	23
		Daily preventive maintenance checks and services	30	23
		Cleaning	31	24
		Removal and replacement of air filter	32	24
CHAPTER	5.	EQUIPMENT SERVICEABILITY CRITERIA		
		Purpose	33	25
		Scope of equipment serviceability criteria	34	25
		Categories of equipment serviceability	35	25
		Inspection and maintenance worksheet	36	25
		Test conditions	37	25
		Test items	38	26

*This manual supersedes TM 11-5820-295-10, 3 June 1960, including C2, 15 December 1961, and C3, 2 April 1963.

		Paragraph	Page
CHAPTER	6.	MATERIEL USED IN CONJUNCTION WITH AN/GRC-19	
		Purpose of additional materiel	39 28
		Remote control operation	40 28
		Antenna groups to extend communication range	41 29
CHAPTER	7.	DEMOLITION OF MATERIEL TO PREVENT ENEMY USE	
		Authority for demolition	42 31
		Methods of destruction	43 31
		Handling, storage, and disposal of radioactive material	44 31
APPENDIX	I.	REFERENCES	32
	II.	BASIC ISSUE ITEMS LIST	33

This page left blank intentionally.

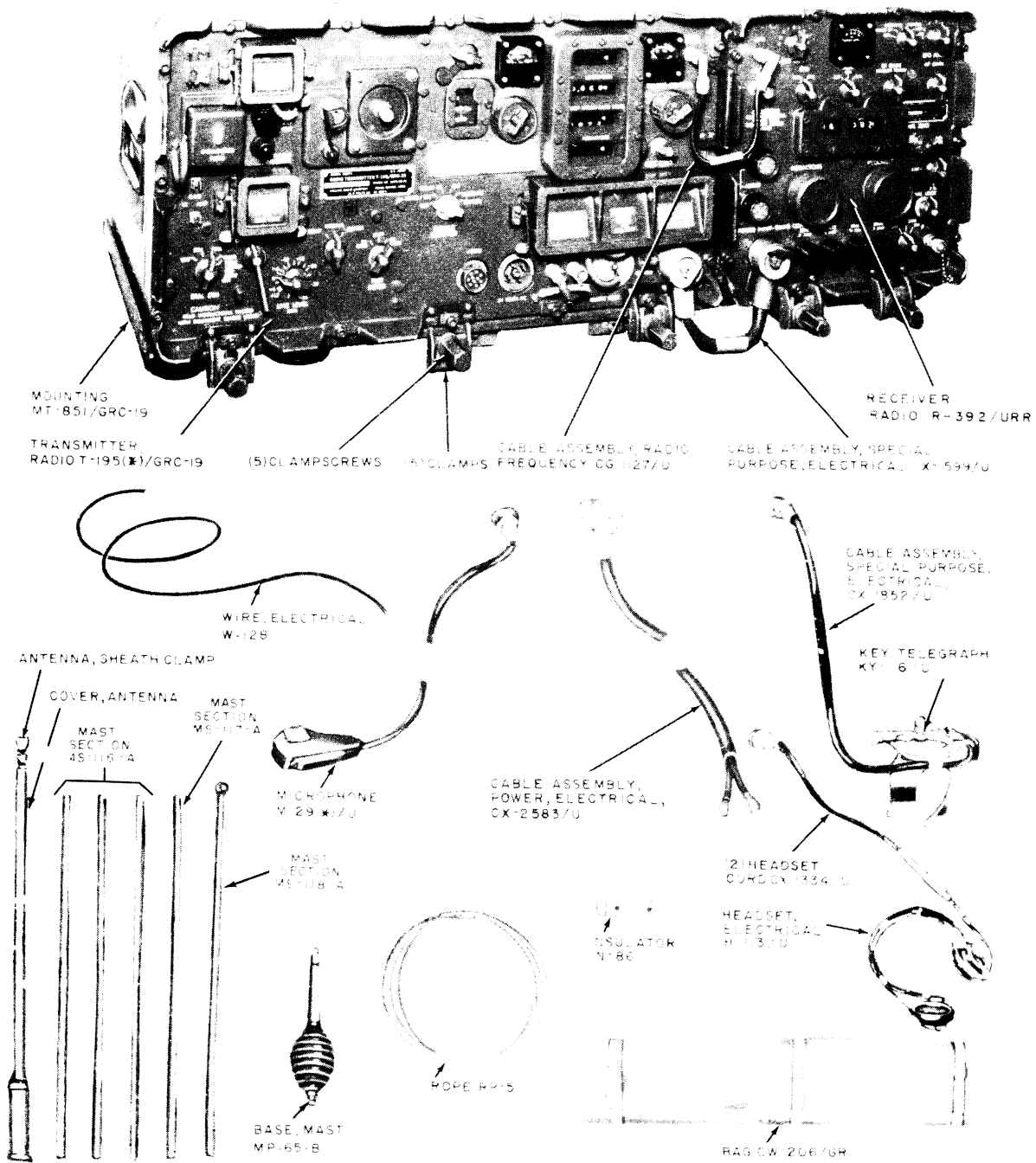

TM5820-295-10-1

Figure 1. Radio Set AN/GRC-19.

CHAPTER 1

INTRODUCTION

Section I. GENERAL

1. Scope

a. This manual describes Radio Set AN/GRC-19 (fig. 1) and covers its operation, operator's maintenance, cleaning and inspection of the equipment, and the Equipment Serviceability Criteria. It includes information on materiel used in conjunction with Radio Set AN/GRC-19, and demolition procedures.

b. For detailed information on Receiver, Radio R-392/URR and Transmitter, Radio T-195(*)/GRC-19, components of Radio Set AN/GRC-19, refer to TM 11-5820-335-10, and TM 11-5820-334-10.

c. The maintenance allocation chart (MAC) is contained in TM 11-5820-295-20.

d. Official nomenclature followed by (*) is used to indicate all models of the equipment covered in this manual. Thus, Transmitter, Radio T-195(*)/GRC-19 represents Transmitters, Radio T-195/GRC-19, T-195A/GRC-19, and T-195B/GRC-19. Microphone M-29(*)/U represents Microphones M-29/U and M-29A/U.

2. Index of Publications

Refer to the latest issue of DA Pam 310-4 to determine whether there are new editions, changes, or additional publications pertain-

ing to your equipment. Department of the Army Pamphlet No. 310-4 is an index of current Technical Manuals, Technical Bulletins, Supply Bulletins, Lubrication Orders, and Modification Work Orders that are available through publications supply channels. The index lists the individual parts (-10, -20, -35P, etc) and the latest changes and revisions of each equipment publication.

3. Forms and Records

a. *Reports of Maintenance and Unsatisfactory Equipment.* Use equipment forms and records in accordance with instructions in TM 38-750.

b. *Report of Damaged or Improper Shipment.* Fill out and forward DD Form 6 (Report of Damaged or Improper Shipment) as prescribed in AR 700-58 (Army), NAVSANDA Publication 378 (Navy), and AFR 71-4 (Air Force).

c. *Comments on Manual.* Forward all comments on this publication direct to: Commanding Officer, U. S. Army Electronics Materiel Support Agency, ATTN: SELMS-MP, Fort Monmouth, New Jersey. (DA Form 1598 (Record of Comments on Publications), DA Form 2496 (Disposition Form), or letter may be used.)

Section II. DESCRIPTION AND DATA

4. Purpose and Use

a. Radio Set AN/GRC-19 provides transmission and reception of continuous-wave (cw) and amplitude-modulated (am.) voice signals. The AN/GRC-19 is designed for vehicular installation with the use of a whip antenna. If the vehicle remains at a site for a period of time, Antenna Group AN/GRA-4 (TM 11-2651) or AN/GRA-50 (TM 11-5820-467-15) can be used in place of the whip antenna to extend the transmitting and receiving ranges.

b. The AN/GRC-19 can be remotely controlled from a distance up to 2 miles through the use of Control Group AN/GRA-6 (para 39 and 40) and can be used to provide relay facilities for two stations that are too far apart to communicate directly with each other (para 21).

5. Technical Characteristics

Warning: Tube type 0A2 or 0A2WA is used in this equipment. These tubes contain radioactive material and are potentially

hazardous when broken. The type and quantity of radioactivity are listed below:

Tube type	Where used	Isotope	Quantity (microcuries)
OA2	Transmitter, Radio T-195(*)/GRC-19	Co60	0.0067
OA2WA	Transmitter, Radio T-195(*)/GRC-19	Ni63 Co60	0.01 - .05 0.0067

Frequency range:
 T-195(*)/GRC-19 1.5 to 20 mc.
 R-392/URR 0.5 to 32 mc.

Types of transmission and reception Cw (A1) and am. voice (A3).

T-195(*)/GRC-19 power output:

15-foot whip antenna . .	1.5 to 2 mc - 13 w. 2 to 3 mc - 28 w. 3 to 4 mc - 45 w. 4 to 5 mc - 60 w. 5 to 6 mc - 90 w. 6 to 9 mc - 100 w. 9 to 16 mc - 90 w. 16 to 20 mc - 80 w.
Antenna Group AN/ GRA-4	1.5 to 12 mc - 100 w. or 12 to 16 mc - 90 w.
Antenna Group AN/ GRA-50	16 to 20 mc - 80 w.

Reliable distance range. . . 50 mi.

Input power requirements:

Starting	250 amps at 28.5 vdc.
Operating	44 amps at 28.5 vdc.
Standby	9 amps. at 28.5 vdc.

6. Components of Radio Set AN/GRC-19

The components of the AN/GRC-19 are listed in the basic issue items list (appx II) and are illustrated in figure 1.

7. Description of Radio Set AN/GRC-19

The T-195(*)/GRC-19 and R-392/URR are the major units that comprise the AN/GRC-19. They are secured to Mounting MT-851/GRC-19 (fig. 2) which is bolted to a vehicular mounting surface.

8. Description of Transmitter, Radio T-195(*)/GRC-19

The T-195(*)/GRC-19 (fig. 1) operating controls and receptacles are mounted on the front panel. Two spring-loaded handles, one on each end of the case, are provided for carrying. One handle at each end of the front panel facilitates removal of the T-195(*)/GRC-19 from its case. The T-195(*)/GRC-19 is fastened in its case by

16 Allen-head screws. The case is recessed on the bottom rear to engage the fixed-position clamps on the MT-851/GRC-19 (fig. 2). The T-195(*)/GRC-19 can be made waterproof during transport or storage by closing the air-intake and exhaust ports used in the forced-air cooling system.

9. Description of Receiver, Radio R-392/URR (fig. 1)

The R-392/URR, housed in an immersion-proof case, is sufficiently ruggedized to withstand conditions encountered in vehicular use. The case is recessed on the bottom rear to engage the fixed-position clamps on the MT-851/GRC-19 (fig. 2). The R-392/URR is fastened into its case by 10 Allen-head screws. All operating controls and electrical connections are on the front panel. Models of the R-392/URR procured on different orders vary in the operation of the front panel DIAL ZERO control. On one model, the DIAL ZERO control must be pushed in before it can be turned. On the other model, the DIAL ZERO control does not have to be pushed in, and can be freely turned.

10. Description of Mounting MT-851/GRC-19 (fig. 2)

The MT-851/GRC-19 serves as a support for the T-195(*)/GRC-19 and R-392/URR. At both ends of the MT-851/GRC-19 are shock-mounted supports which normally are bolted to a vehicular mounting surface. Two grounding straps (not shown), one at the rear of each end, are provided for grounding the MT-851/GRC-19 to the vehicle chassis. Six fixed-position clamps on the top rear of the MT-851/GRC-19 engage the recesses in the rear of the T-195(*)/GRC-19 and R-392/URR cases. Five clamps and clamp screws on the front of the MT-851/GRC-19 secure the T-195(*)/GRC-19 and the R-392/URR to the MT-851/GRC-19.

11. Description of Minor Components

a. *Whip Antenna.* The whip antenna (fig. 1) consists of three Mast Sections MS-116-A, Mast Section MS-117-A, Mast Section MS-118-A, Base, Mast MP-65-B, Cover, Antenna (antenna cover) and one Antenna,

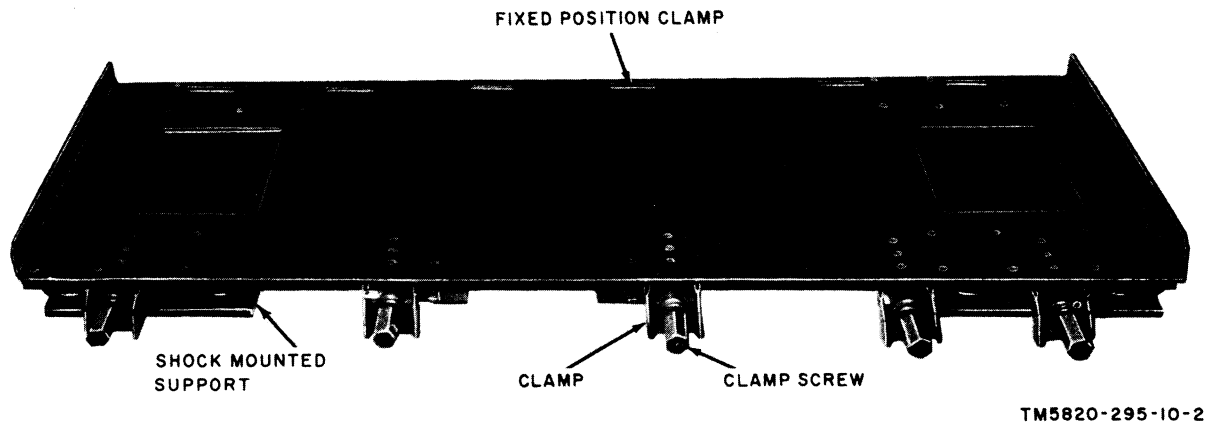

TM5820-295-10-2

Figure 2. Mounting MT-851/GRC-19.

Sheath Clamp (antenna sheath clamp). The mast sections are screwed together, and the assembled sections screwed to the MP-65-B which mounts on a rigid vehicle support. The antenna cover is mounted over the lower mast section (Mast Section MS-116-A) and fastened in place with the antenna sheath clamp.

b. *Rope RP-5*. Rope RP-5 (fig. 1) is a length of rope used with Insulator IN-86 (c below) to tie down the whip antenna (fig. 3).

c. *Insulator IN-86*. Insulator IN-86 is a rectangular, ceramic insulator used to insulate the whip antenna from the vehicle body when Rope RP-5 is used to tie down the whip antenna (fig. 3).

d. *Bag CW-206/GR*. Bag CW-206/GR (fig. 1) is used to store the whip antenna elements (a above) when the whip antenna is disassembled. It is also used to store the other minor components and the technical manuals.

e. *Key, Telegraph KY-116/U*. The KY-116/U (fig. 1) is mounted to a metal clamp which can be attached on the operator's leg. Cable Assembly, Special Purpose,

Electrical CX-1852/U connects the KY-116/U to the AUDIO connector on the T-195(*)/GRC-19.

f. *Headset, Electrical H-113/U*. The H-113/U (fig. 1) consists of two series-connected receivers. A 14-inch cord is connected to the receivers and terminated in Jack JJ-026. The jack mates with Plug PJ-054 on one end of Headset Cord CX-1334/U. Headset Cord CX-1334/U terminates in a 10-pin connector which mates with the AUDIO receptacle on the T-195(*)/GRC-19 or R-392/URR.

g. *Microphone M-29(*)/U*. The M-29(*)/U consists of a carbon element in a plastic case with a push-to-talk switch and connecting cord attached. The push-to-talk switch is a two-position nonlocking switch. The connecting cord is 5 feet long and terminates in a 10-pin connector. This connector mates with the AUDIO receptacle on the T-195(*)/GRC-19 or R-392/URR.

h. *Cable and Cord Assemblies* (fig. 1). The cables and cords used with Radio Set AN/GRC-19 are described in the chart below.

Nomenclature	Connects		Cable termination
	From	To	
Cable Assembly, Special Purpose, Electrical CX-1852/U.	Key, Telegraph KY-116/U.	T-195(*)/GRC-19 AUDIO connector.	Ten-pin audio connector on one end, two spade lugs on the other.
Cable Assembly, Special Purpose, Electrical CX-1599/U.	R-392/URR POWER INPUT-TRANS CONT connector.	T-195(*)/GRC-19 RECEIVER CONT connector.	Nine-pin, right-angle connector on each end.
Headset Cord CX-1334/U.	Plug PJ-054 on Headset, Electrical H-113/U.	R-392/URR AUDIO connector.	Ten-pin audio connector on one end, Jack JJ-026 on the other.

Nomenclature	Connects		Cable termination
	From	To	
Cable Assembly, Radio Frequency CG-1127/U.	T-195(*)/GRC-19 RECEIVER ANTENNA connector.	R-392/URR ANT connector.	Plug, Connector UG-913/U on each end.
Cable Assembly, Power, Electrical CX-2583/U.	T-195(*)/GRC-19 24 VOLTS DC connector.	Dc voltage source ---	Two spade lugs on one end, four-pin right-angle connector on the other.
Wire, Electrical W-128.	T-195(*)/GRC-19 WHIP ANTENNA connector.	Binding post on Base, Mast MP-65-B.	None.

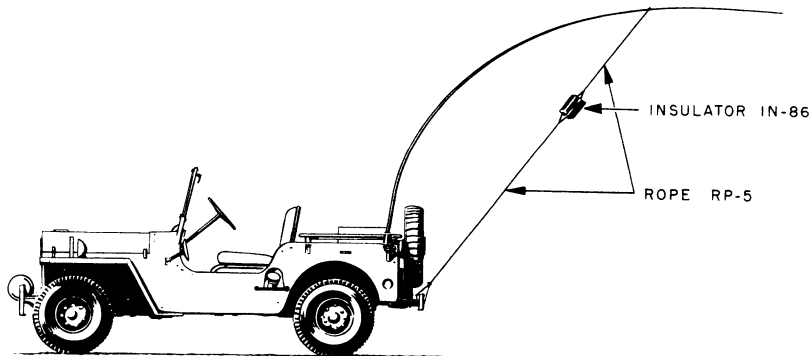

TM5820-295-10-10

Figure 3. Whip antenna tied down, using Rope RP-5 and Insulator IN-86.

12. System Applications

Three methods of operation are available to the operator of the AN/GRC-19; normal (simplex), duplex, and relay.

a. Normal Operation. Normal operation of the AN/GRC-19 (fig. 4) is a method of operation in which communication between two stations takes place in one direction at a time. This includes voice (push-to-talk) or cw operation. A single antenna is used for both transmitting and receiving at each terminal. A single frequency, or two separate frequencies may be used; one for transmitting, the other for receiving.

b. Duplex Operation. Duplex operation of the AN/GRC-19 (fig. 5) is a method of operation in which simultaneous transmission and reception of voice or cw takes place. During duplex operation, a separate frequency and a separate antenna is used for receiving and transmitting. The frequencies

used must be separated by at least 1 megacycle.

c. Relay Operation. There are two types of relay operation available; normal and duplex.

(1) *Normal relay.* During normal relay operation (fig. 6), a single antenna is used for both transmitting and receiving at each terminal station. Two antennas are required at the relay station. Two frequencies separated by at least 1 megacycle *must* be used.

(2) *Duplex relay.* During duplex relay operation (fig. 7), two antennas are required at each terminal station and four antennas at the relay station. Transmission and reception can be done simultaneously. Four frequencies separated by at least 1 megacycle *must* be used.

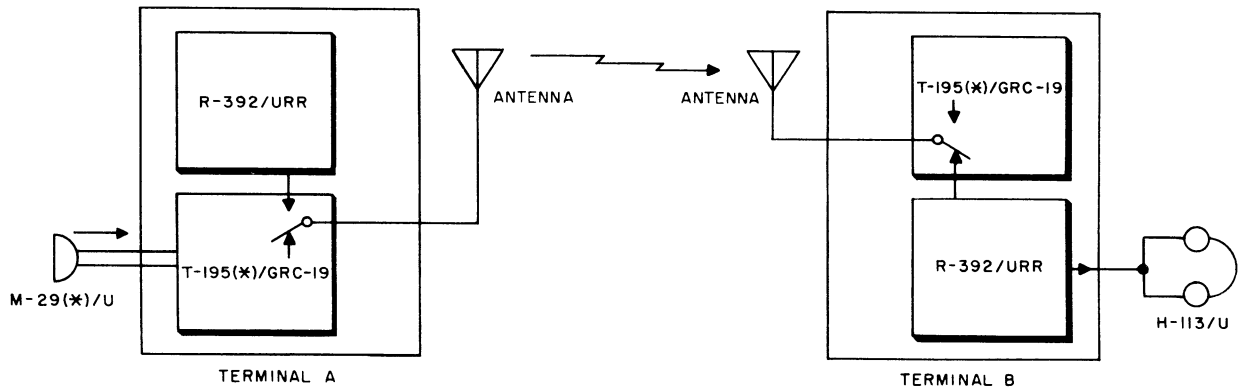

A. TERMINAL A SENDING TO TERMINAL B

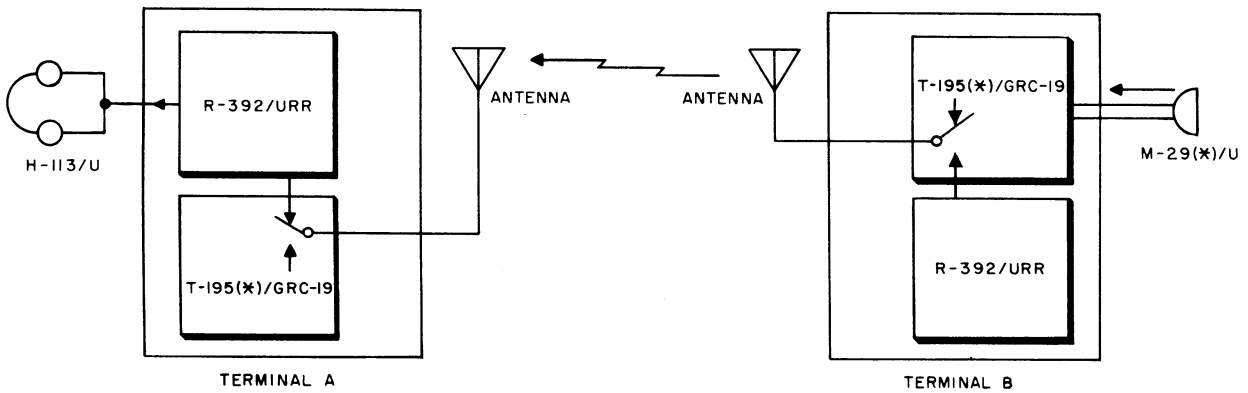

B. TERMINAL B SENDING TO TERMINAL A

TM5820-295-10-12

Figure 4. Normal operation, simplified block diagram.

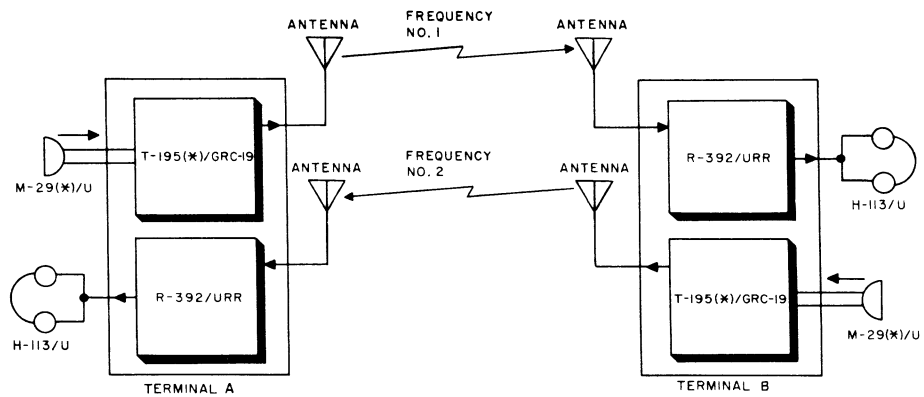

TM5820-295-10-13

Figure 5. Duplex operation, simplified block diagram.

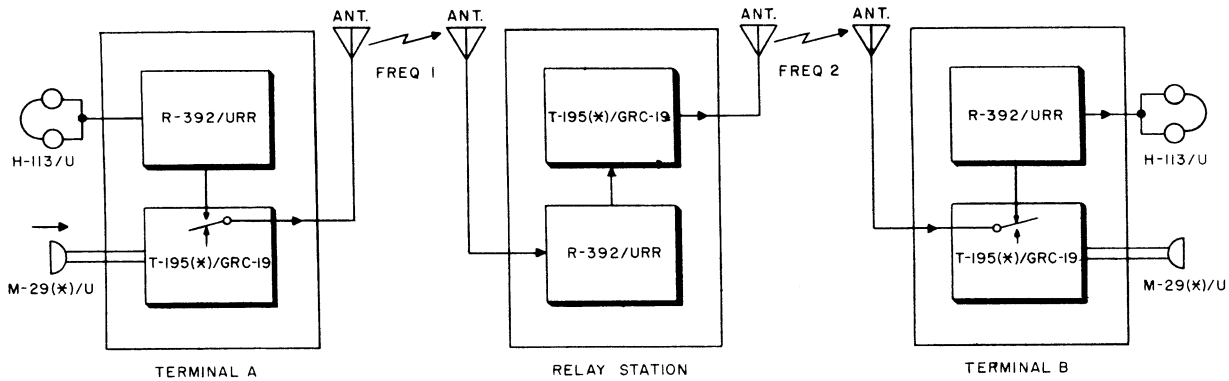

A. TERMINAL A SENDING TO TERMINAL B

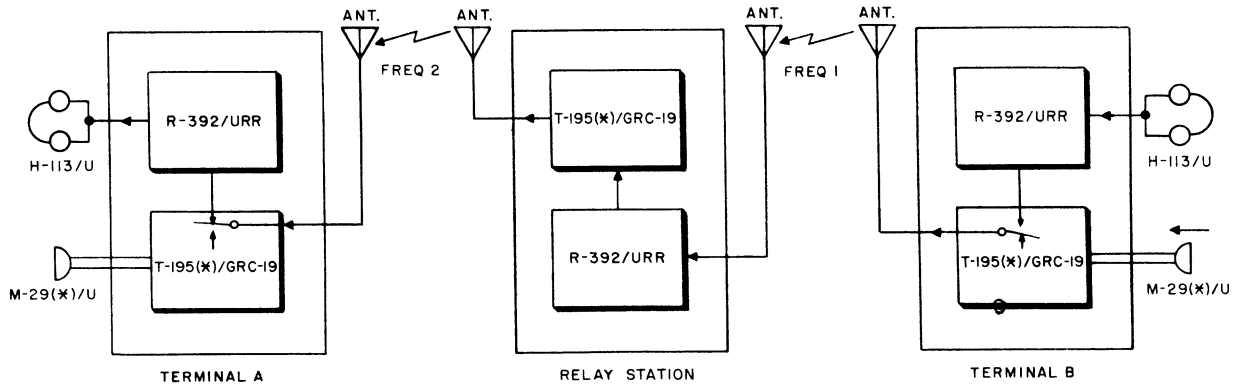

B. TERMINAL B SENDING TO TERMINAL A

TM5820-295-10-5

Figure 6. Normal relay operation, simplified block diagram.

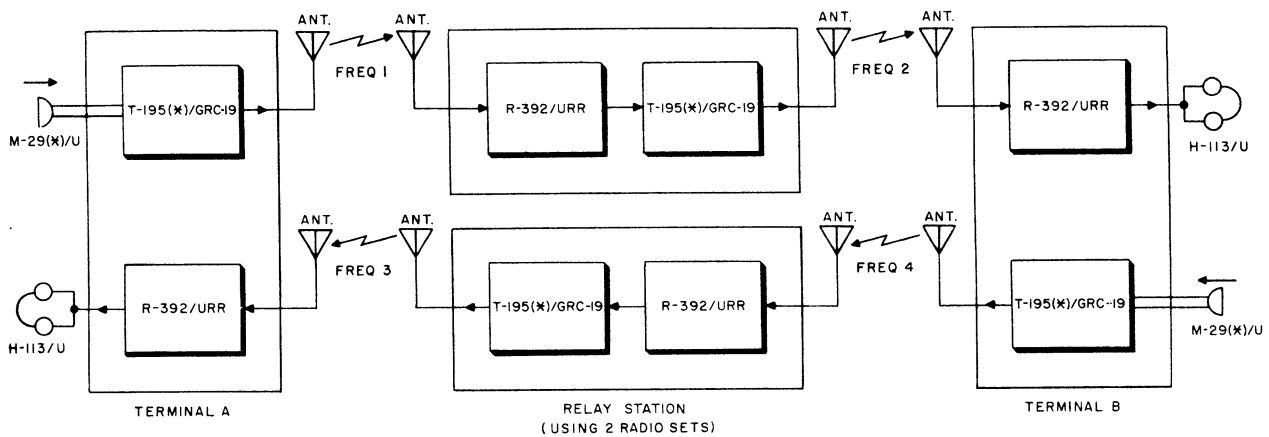

FULL-DUPLEX RELAY OPERATION
TERMINAL A AND TERMINAL B SENDING AND RECEIVING AT THE SAME TIME

TM5820-295-10-14

Figure 7. Duplex relay operation, simplified block diagram.

CHAPTER 2

INSTALLATION

13. General

The original installation of Radio Set AN/GRC-19 is performed at a higher echelon, but it will be necessary for the operator to remove the T-195(*)/GRC-19 and R-392/URR from the MT-851/GRC-19 in the vehicle for maintenance, protection from inclement weather, or safeguarding of the equipment when the carrying vehicle is unattended for prolonged periods of time. Paragraphs 14 through 16 describe the procedure for removal and replacement of the T-195(*)/GRC-19 and R-392/URR, installation of the whip antenna, and cabling.

14. Removal and Replacement of T-195(*)/GRC-19 and R-392/URR from MT-851/GRC-19

Warning: Voltages dangerous to life are used in this equipment. Before connecting or disconnecting any cables, be sure that the T-195(*)/GRC-19 SERVICE SELECTOR switch (fig. 9) is at OFF.

Note: Two men are required to lift the T-195(*)/GRC-19 when it is removed from, or replaced on, the MT-851/GRC-19.

a. Removal.

- (1) Remove all cables and audio accessories connected to the T-195(*)/GRC-19 and R-392/URR (fig. 8).
- (2) Release the five clamps on the front of the MT-851/GRC-19 (fig. 2) by turning the clamp screws counterclockwise.
- (3) Slide the T-195(*)/GRC-19 and the R-392/URR off the MT-851/GRC-19.
- (4) Tighten the clamp screws by turning them fully clockwise.

b. Replacement.

- (1) Release the five clamps on the front of the MT-851/GRC-19 by turning the clamp screws counterclockwise.
- (2) Slide the T-195(*)/GRC-19 onto the left-hand side of the MT-851/GRC-19 so that the lower rear edge of the T-195(*)/GRC-19 case engages the four fixed-position clamps at the

- (3) Slide the R-392/URR onto the right-hand side of the MT-851/GRC-19 so that the lower rear edge of the R-392/URR case engages the two fixed-position clamps at the rear of the MT-851/GRC-19.
- (4) Set the five MT-851/GRC-19 clamps so that they engage the plate recesses on the lower front edges of the T-195(*)/GRC-19 and the R-392/URR.
- (5) Tighten the five clamp screws.

15. Whip Antenna Installation

a. *Assembly* (fig. 1). Assemble the mast sections as follows:

- (1) Screw together three MS-116-A sections.
- (2) Screw the MS-117-A section into the top MS-116-A section.
- (3) Screw the MS-118-A section into the MS-117-A section.
- (4) Slide the antenna sheath clamp and the antenna cover up over the lowest section of the MS-116-A.
- (5) Screw the MS-116-A section (on the end of the partly assembled antenna) into Base, Mast MP-65-B.
- (6) Slide the antenna cover down onto the MP-65-B.
- (7) Slide the antenna sheath clamp down to the antenna cover and tighten it over the top.

b. *Whip Antenna Tiedown.* Use Rope RP-5 and Insulator IN-86 to tie the antenna to the vehicle as shown in figure 3.

16. External Connections

For normal operation (para 12a), connect the AN/GRC-19 as shown in figure 8. For duplex or relay operation (para 12b and c) omit the connection between the RECEIVER ANTENNA connector on the T-195(*)/GRC-19 and the ANT connector on the R-392/URR. Connect the receive antenna to either ANT connector on the R-392/URR.

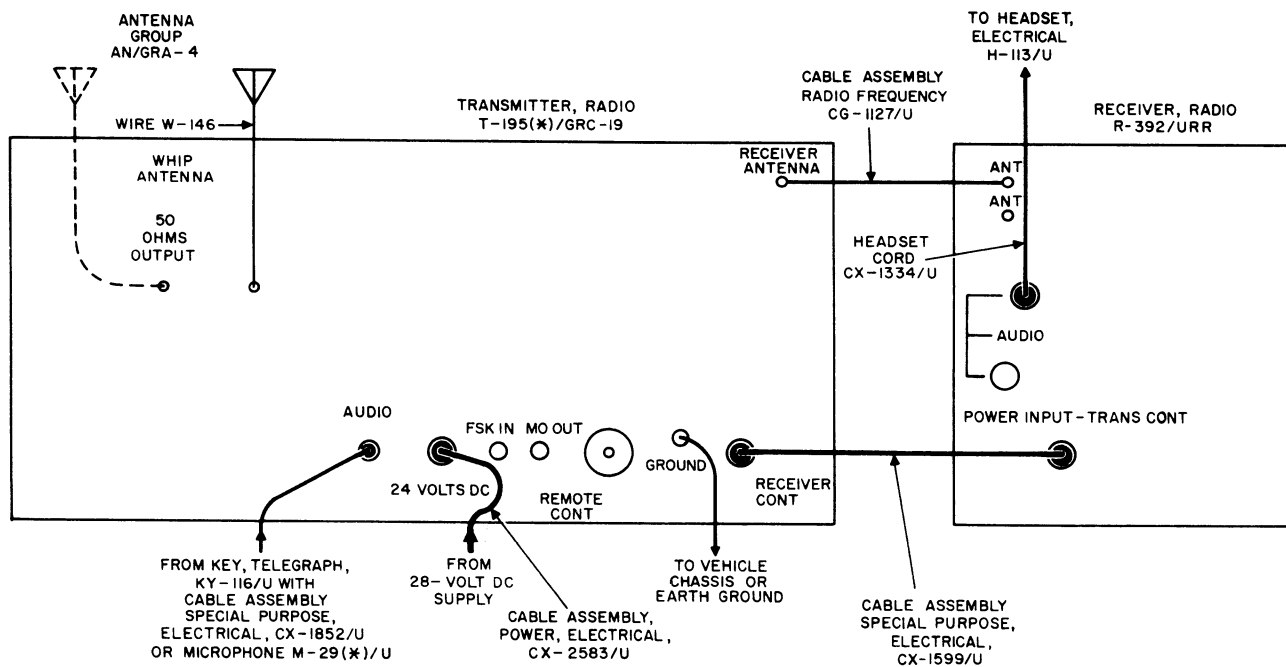

NOTE:
ANTENNA GROUP AN/GRA-4 (SHOWN IN
DOTTED LINES) IS NOT SUPPLIED AS PART
OF RADIO SET AN/GRC-19.

TM5820-295-10-17

Figure 8. Radio Set AN/GRC-19 cording diagram for normal operation.

CHAPTER 3

OPERATING INSTRUCTION

Section I. OPERATOR'S CONTROLS AND INDICATORS

17. Damage From Improper Settings

Observe the following precautions when setting the front panel controls:

a. Do not turn the T-195(*)/GRC-19 SERVICE SELECTOR switch while the automatic channel selection system is cycling.

b. Be careful when setting the R-392/URR MEGACYCLES control. On some R-392/URR's the stop mechanism fails to provide a positive stop. The limits between which the MEGACYCLE control may be rotated without damage are 00 and 31 megacycles (mc).

c. Be careful when setting the R-392/URR KILOCYCLES control. Do not turn the KILOCYCLES control beyond 000 in the counter-clockwise direction or beyond 999 in the clockwise direction.

18. Transmitter, Radio T-195(*)/GRC-19 Controls and Indicators (fig. 9)

Control or indicator	Function
SERVICE SELECTOR switch.	Six-position switch:
	<i>Sw pos</i> <i>Function</i>
	OFF Turns off power
	VOICE/FSK Permits voice or radio teletype-writer operation.
	STAND BY Applies power to the tube filaments and blower motor.
	CW Permits cw operation.
CALIBRATE Couples signal to R-392/URR for calibration of the T-195(*)/GRC-19.	
REMOTE Used with Control Group AN/GRA-6 (para 40).	
RELAY-NORMAL-DUPLEX switch.	Three-position switch:
	<i>Sw pos</i> <i>Function</i>
	NORMAL Provides both transmission and reception, but not at the same time.
	RELAY Provides relay operation.
DUPLEX Provides simultaneous transmission and reception.	
BAND SELECTOR control.	Selects the operating frequency band.

Control or indicator	Function
Band-channel indicator.	Shows the preset channel selected and the low and high frequency ends of the band selected by the BAND SELECTOR control.
Frequency indicator--	Shows the frequency to which the T-195(*)/GRC-19 is tuned.
Band selector locking bar.	Locks the BAND SELECTOR switch.
TUNING CONTROL --	Tunes the T-195(*)/GRC-19 to the desired frequency in the selected band.
Tuning control locking bar.	Locks TUNING CONTROL.
DIAL ZERO control --	Permits calibration of the frequency indicator.
PRESET CHANNELS switch.	Selects a preset or manual channel.
Reminder spring-----	Locks the PRESET CHANNELS switch in the M (manual) position. (Reminder spring tab must be pressed to release the PRESET CHANNELS switch from the M position.)
Test meter -----	Indicates voltages or currents in circuits selected by the TEST METER switch.
TEST METER switch	Three-position switch that selects circuits to be measured by the test meter.
	<i>Sw pos</i> <i>Function</i>
PA GRID	Indicates power amplifier grid current.
BATT	Indicates battery voltage.
PA CATH	Indicates power amplifier cathode current.
Audio level meter----	Indicates percentage of modulation and audio level in volume units (VU).
LINE LEVEL control	Adjusts the level of audio signal from the R-392/URR during radio relay operation.
TEST KEY -----	When held at ON, keys the T-195(*)/GRC-19 for testing purposes.
TUNING INDICATOR	Lights when the automatic tuning cycle has been completed.
DIAL DIM switch ----	Four-position switch that controls the brightness of the dial lamps and TUNING INDICATOR.
	<i>Sw pos</i> <i>Function</i>
OFF	Dial lights are out.
DIM	Dial lights are dimly lighted.
FULL	Dial lights are bright.
OVER HEAT CHECK-RED LIGHT ON	TUNING INDICATOR lights if the T-195(*)/GRC-19 is overheated.

19. Transmitter, Radio T-195(*)/GRC-19
Front Panel Connectors
(fig. 9)

Connector	Function
WHIP ANTENNA-----	Used for connecting a whip antenna.
50 OHMS OUTPUT---	Used for connecting the doublet antenna (Antenna Group AN/GRA-4).
RECEIVER ANTENNA	Used for connecting the R-392/URR to the T-195(*)/GRC-19 antenna.
AUDIO -----	Used for connecting the M-29(*)/U or KY-116/U to the T-195(*)/GRC-19.
24 VOLTS DC -----	Used to apply the input power to the AN/GRC-19.
FSK IN -----	Not used.
MO OUT -----	Not used.
REMOTE CONT -----	Not used.
RECEIVER CONT ---	Used to connect the R-392/URR to the T-195(*)/GRC-19.
GROUND -----	Grounds the T-195(*)/GRC-19.

20. Receiver, Radio R-392/URR Controls, Indicators, and Connectors
(fig. 10)

Control, indicator, or connector	Function
Function switch ----	<p>Six-position switch.</p> <p><i>Sw pos</i> <i>Function</i></p> <p>OFF Turns off power to the R-392/URR.</p> <p>STAND BY Applies power to tube filaments.</p> <p>NORMAL Sets up R-392/URR for normal operation.</p> <p>LIMITER Reduces static. Has little effect on static when receiving weak signals.</p> <p>NET Permits simultaneous operation of the R-392/URR and an associated T-195(*)/GRC-19.</p> <p>SQ (squelch) Prevents noise from being heard when a signal is not being received. The minimum signal level which can be received in the SQ position is determined by the position of the RF GAIN SQUELCH THRESH control.</p>
Frequency indicator	Shows the frequency in megacycles or kilocycles to which the R-392/URR is tuned. Megacycles are indicated in the first two spaces of the frequency indicator. Kilocycles are indicated in the last three spaces of the frequency

Control, indicator, or connector	Function
MEGACYCLES control	indicator. (The R-392/URR shown in figure 10 is tuned to 29,111 kilocycles.) Changes the tuning range of the receiver in steps of 1 megacycle.
KILOCYCLES control	Tunes the R-392/URR.
RF GAIN SQUELCH THRESH control.	Adjusts audio level at the headset by controlling the strength of the received signal when the function switch is in NORMAL, LIMITER, OR NET. Establishes the minimum required signal strength to make the receiver operable when the function switch is set to SQ.
AF GAIN control-----	Controls the audio frequency signal level.
CARRIER LEVEL meter.	Indicates relative strength of received signal when the AGC switch is set to ON or CAL.
ANT TRIM control ---	Tunes the antenna input circuit. Should be adjusted for maximum signal strength.
ANT connector (upper) and ANT binding post and (lower connector).	Used to connect the antenna to the R-392/URR. Either connector can be used.
BFO switch -----	In ON position, permits reception of cw signals.
BFO PITCH control --	Adjusts the pitch of the received CW signals when the BFO switch is ON.
AGC switch -----	In ON position, keeps the signal level nearly the same regardless of the strength of the signal being received. In OFF position, disables the automatic gain control (agc) circuit. In CAL position, provides calibration signals for checking or adjusting the frequency indicator.
DIAL ZERO control --	Adjusts the frequency indicator dial to correct for small errors in frequency indicator.
DIAL LOCK control --	Locks the KILOCYCLES control.
BAND WIDTH switch	At 2KC, reduces interference caused when unwanted signals are too close in frequency to the wanted signal. At 4KC, reduces interference but not as much as in the 2 KC position. At 8KC, voice signals will have better tone quality in this position. Used when interference is not objectionable.
DIAL DIM switch ----	In ON position, turns frequency indicator lamp on. In OFF position, turns frequency indicator lamp off. At midposition, causes frequency indicator lamp to be dim.
IF OUT connector----	Not used.
AUDIO receptacles (2)	Used to connect the H-113/U. Both receptacles are identical, either may be used.
POWER INPUT-TRANS CONT receptacle.	Used to apply power to the R-392/URR from the T-195(*)/GRC-19.

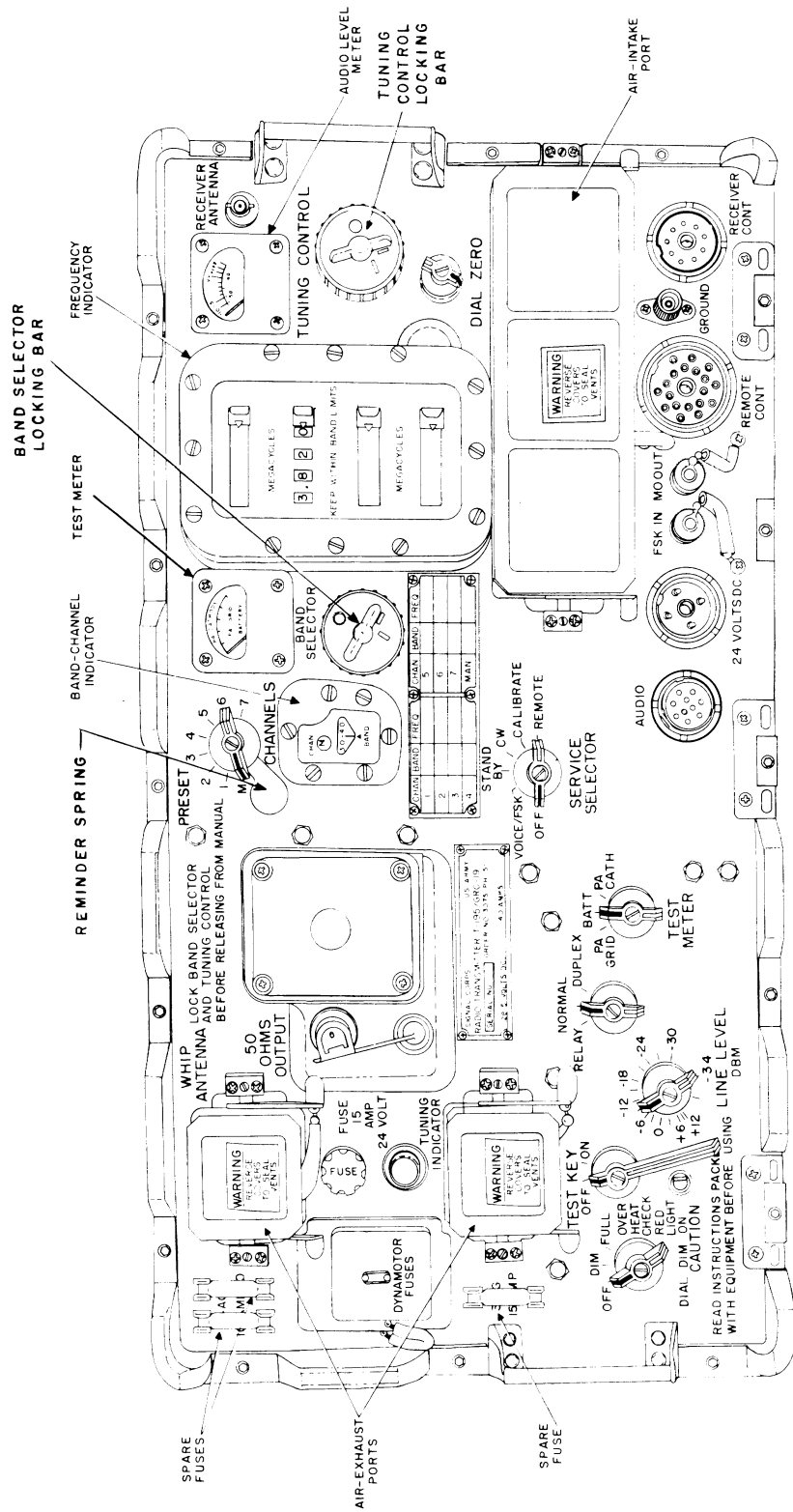

TM5R20 - 293 - 10 - 18

Figure 9. Transmitter, Radio T-195(*)/GRC-19 controls, indicators, and connectors.

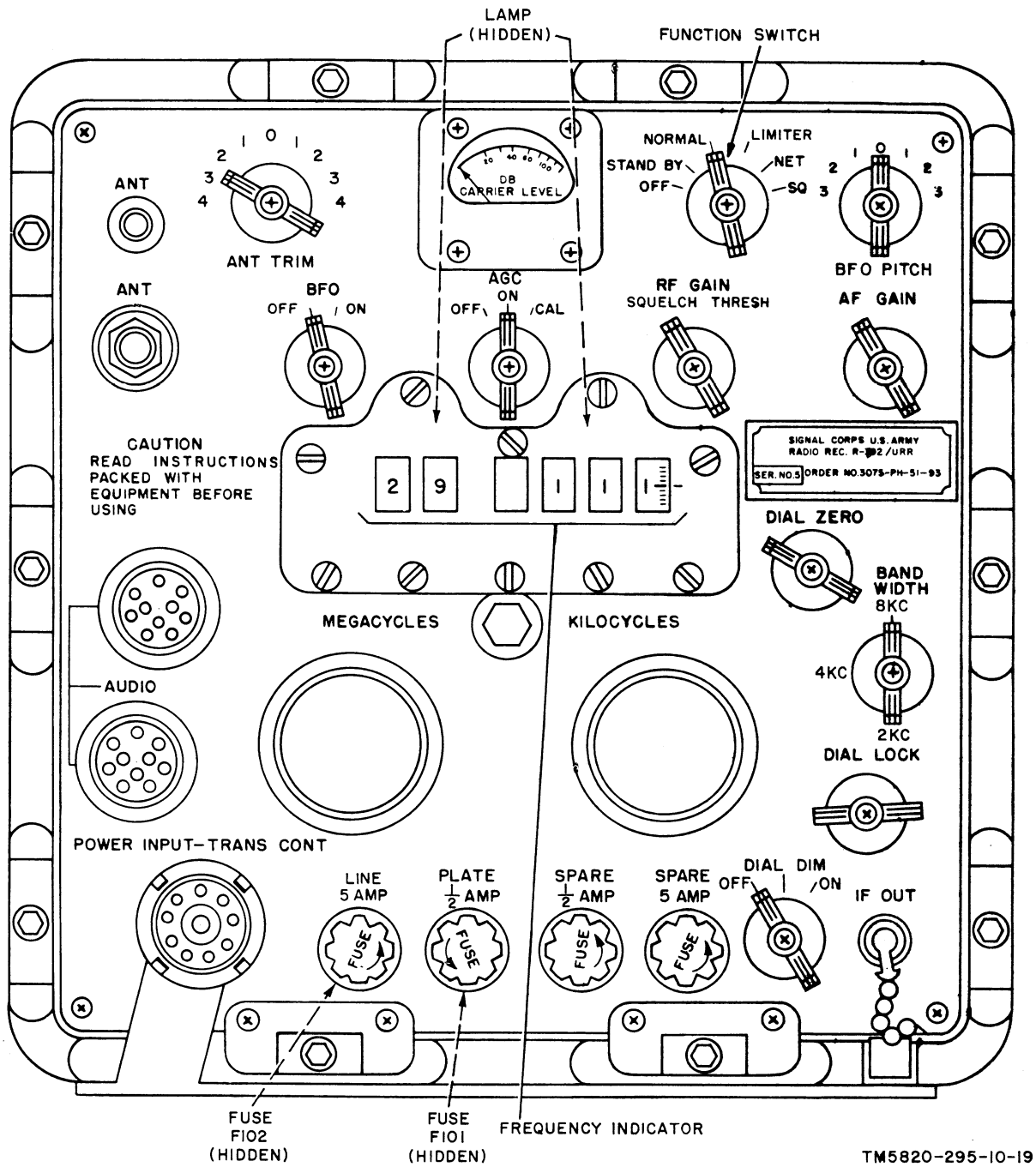

Figure 10. Receiver, Radio R-392/URR front panel controls, indicators, and connectors.

Section II. OPERATION

21. Types of Operation

The radio set may be used as a terminal or relay station in a simplex (normal) or duplex radio circuit for either voice or cw operation. Refer to paragraph 12 for a detailed discussion of the types of operation possible with Radio Set AN/GRC-19.

22. Starting Procedures for AN/GRC-19

a. Preliminary Starting Procedures.

- (1) Connect the H-113/U to the AUDIO connector on the R-392/URR.
- (2) Open the air exhaust and intake ports on the T-195(*)/GRC-19.
- (3) Connect the M-29(*)/U (voice operation) or the KY-116/U (cw operation) to the AUDIO connector on the T-195(*)/GRC-19.
- (4) Preset the R-392/URR front panel controls and switches as follows:
 - (a) BFO switch to OFF.
 - (b) AGC switch to ON.
 - (c) RF GAIN SQUELCH THRESH control maximum clockwise.
 - (d) AF GAIN control to midposition.
 - (e) DIAL LOCK control maximum counterclockwise.

- (f) BAND WIDTH control to 8KC.
 - (g) DIAL ZERO control maximum counterclockwise.
 - (h) Function switch to STAND BY.
 - (i) DIAL-DIM switch to ON.
 - (j) BFO PITCH control to 0.
- (5) Preset the T-195(*)/GRC-19 front panel controls and switches as follows:
- (a) DIAL-DIM switch to FULL.
 - (b) TUNING CONTROL and BANDSELECTOR locking bars fully clockwise.
 - (c) SERVICE SELECTOR switch to STANDBY.
 - (d) RELAY - NORMAL - DUPLEX switch to NORMAL.

b. *Calibration, Tuning, and Frequency Presetting.* The T-195(*)/GRC-19 can be preset to eight different channels. Perform the procedures in steps 1 through 24 to preset any or all of the eight channels. One channel at the M position can be used for manual tuning purposes. Each preset channel *must* be calibrated as outlined in steps 20 through 24. Perform the procedures outlined in the chart below to calibrate, tune, and frequency preset the AN/GRC-19.

Step	Control or switch	Action	Indication
R-392/URR CALIBRATION AND TUNING			
1	R-392/URR function switch -----	Set to NORMAL -----	Frequency dial lamp lights. Rushing noise is heard in H-113/U.
2	R-392/URR BFO switch -----	Set to ON -----	None.
3	R-392/URR AGC switch -----	Set to CAL -----	None.

Note: There are two models of the R-392/URR (para 9). Steps 4 through 9 cover the calibration and tuning procedures for the "turn" type DIAL ZERO control, and steps 10 through 15 cover the "push-in" type.

4	Caution: Turn DIAL LOCK control counterclockwise until it stops before turning the KILOCYCLES control. R-392/URR MEGACYCLES and KILOCYCLES controls.	Turn to 100-kc point nearest operating frequency.	Frequency appears in frequency indicator ending in 00 indication. Tone will be heard in H-113/U.
5	R-392/URR DIAL ZERO control --	Turn fully clockwise -----	DIAL ZERO control is locked. Kilocycles dial indication is locked.
6	R-392/URR KILOCYCLES control	Adjust for zero beat indication ---	The 00 indication in frequency indicator will not change; tone is lost.
7	Caution: Do not force the control past the stop. Damage to the DIAL ZERO locking plate will result.		

Step	Control or switch	Action	Indication
	R-392/URR DIAL ZERO control --	Turn fully counterclockwise -----	DIAL ZERO control is unlocked. Kilocycles dial indication can be changed with rotation of KILOCYCLES control.
8	R-392/URR KILOCYCLES control	Adjust until desired operating frequency appears in frequency indicator.	Desired operating frequency appears in frequency indicator.
9	R-392/URR BFO switch -----	Set to OFF -----	None.
10	Caution: Turn DIAL LOCK control counterclockwise until it stops before turning the KILOCYCLES control. R-392/URR MEGACYCLES and KILOCYCLES controls.	a. Adjust until tone is heard at 100-kc point nearest operating frequency. b. Adjust kilocycles control for zero beat indication in H-113/U.	a. Tone will be heard in H-113/U. b. Tone is lost.
11	R-392/URR DIAL LOCK control --	Turn fully clockwise -----	KILOCYCLES control is locked.
12	R-392/URR DIAL ZERO control --	Push in; adjust until frequency indicated in frequency indicator ends in 00.	Frequency appears in frequency indicator ending in 00 indication.
13	R-392/URR DIAL LOCK control --	Turn fully counterclockwise -----	KILOCYCLES control is unlocked.
14	R-392/URR KILOCYCLES control	Adjust until desired operating frequency appears in frequency indicator.	Desired operating frequency appears in frequency indicator.
15	R-392/URR BFO switch -----	Set to OFF -----	None.

T-195(*)/GRC-19 FREQUENCY PRESETS

16	T-195(*)/GRC-19 TEST METER switch.	Set to BATT -----	Test meter indicates on midpoint of BATTERY scale.
17	Caution: Do not change the setting of the PRESET CHANNELS switch while the BAND SELECTOR and TUNING CONTROL are cycling. Damage to the tuning system will occur. T-195(*)/GRC-19 PRESET CHANNELS switch.	Set to desired channel ----- <i>Note:</i> Reminder spring must be depressed to turn from M position.	TUNING CONTROL and BAND SELECTOR switches rotate to frequency formerly preset at this position.
18	T-195(*)/GRC-19 BAND SELECTOR switch.	a. Unlock BAND SELECTOR locking bar by turning it counterclockwise. b. Adjust BAND SELECTOR switch to assigned band. c. Lock BAND SELECTOR locking bar by turning it fully clockwise.	a. BAND SELECTOR switch is unlocked. b. Assigned frequency band appears in band-channel indicator. c. BAND SELECTOR switch is locked.
19	T-195(*)/GRC-19 TUNING CONTROL.	a. Unlock TUNING CONTROL locking bar by turning it counterclockwise. b. Adjust TUNING CONTROL until the assigned frequency appears on frequency indicator. c. Lock TUNING CONTROL locking bar by turning it fully clockwise.	a. TUNING CONTROL is unlocked. b. Assigned frequency appears in frequency indicator. c. TUNING CONTROL is locked.

Step	Control or switch	Action	Indication
T-195(*)/GRC-19 CALIBRATION			
20	T-195(*)/GRC-19 SERVICE SELECTOR switch.	Set to CALIBRATE -----	None.
21	R-392/URR function switch -----	Set to NET -----	None.
22	R-392/URR BFO switch -----	Set to ON -----	None.
23	T-195(*)/GRC-19 TUNING CONTROL.	a. Unlock TUNING CONTROL locking bar by turning it counterclockwise. b. Adjust TUNING CONTROL for zero beat indication in H-113/U. c. Lock TUNING CONTROL locking bar by turning it fully clockwise.	a. TUNING CONTROL is unlocked. b. Zero beat indication is obtained in H-113/U. Operating frequency observed in frequency indicator must be same as that indicated on R-392/URR frequency indicator. If not, perform step 24 below. c. TUNING CONTROL is locked.
24	T-195(*)/GRC-19 DIAL ZERO control.	Push in; turn until desired frequency is observed on T-195(*)/GRC-19 frequency indicator.	Desired operating frequency appears in frequency indicator.
TUNING			
25	T-195(*)/GRC-19 TEST METER switch.	Set to PA GRID -----	None.
26	T-195(*)/GRC-19 PRESET CHANNELS switch.	Set to channel number corresponding to desired operating frequency.	Complete automatic tuning cycle should be completed. Preset band and frequency should appear in band channel indicator and frequency indicator. Test meter should indicate within shaded area marked PA GRID.
27	T-195(*)/GRC-19 TEST METER switch.	Set to PA CATH -----	None.
28	T-195(*)/GRC-19 SERVICE SELECTOR switch.	Set to CW -----	Test meter should indicate zero.
29	T-195(*)/GRC-19 TEST KEY -----	Hold at ON -----	TUNING INDICATOR lamp should light, and remain lighted after tuning cycle is complete. Test meter should indicate in shaded area marked PA CATHODE. <i>Note:</i> TUNING INDICATOR may flash sporadically, and current indication on test meter may fluctuate between, below, and above normal values before tuning cycle is complete. If T-195(*)/GRC-19 has been manually tuned from one frequency to another in same band, TUNING INDICATOR may not light. In this case, switch BAND SELECTOR switch to an adjacent band and back again and wait for tuning cycle to be completed.
30	T-195(*)/GRC-19 SERVICE SELECTOR switch.	Set to STAND BY -----	None.

23. Operational Procedures

Before operating the AN/GRC-19 perform the tuning, calibration, and frequency preset procedures as outlined in paragraph 22.

a. *Normal Operation.* Set the T-195(*)/

GRC-19 RELAY-NORMAL-DUPLEX switch to NORMAL, then perform the procedures as outlined in steps 1 through 11 in the chart *d* below.

b. *Duplex Operation.* Set the T-195(*)/

GRC-19 RELAY-NORMAL-DUPLEX switch to DUPLEX, then perform the procedures as outlined in steps 1 through 11 in the chart *d* below.

c. Relay Operation.

(1) *Terminal station.* Set the T-195(*)/GRC-19 RELAY-NORMAL-DUPLEX switch to NORMAL for normal relay operation, or to DUPLEX for duplex relay operation, then perform the procedures as outlined in steps 1 through 11 in the chart *d* below.

(2) *Relay station.* Set the T-195(*)/GRC-19 RELAY-NORMAL-DUPLEX switch to NORMAL for normal relay operation, or to DUPLEX for duplex relay operation, then perform the procedures as outlined in steps 1 through 15 in the chart below.

d. Operation of AN/GRC-19.

Note: Items 1 through 5 in the chart below are pre-set before on-the-air transmission with another station.

Step	Control or switch	Action	Indication
1	R-392/URR function switch -----	Set to NORMAL -----	A rushing noise is heard in H-113/U.
2	R-392/URR AGC switch -----	a. Set to ON for voice operation -- b. Set to OFF for cw operation ---	a. None. b. None.
3	R-392/URR BFO switch -----	a. Set to OFF for voice operation b. Set to ON for cw operation ----	a. None. b. None.
4	T-195(*)/GRC-19 SERVICE SELECTOR switch.	a. Set to VOICE/FSK for voice operation. b. Set to CW for cw operation ----	a. None. b. None.
5	M-29(*)/U (voice) or KY-116/U (cw).	a. For voice operation: Hold the M-29(*)/U about 2 inches from the lips, press the push-to-talk switch, and speak in normal voice. b. For cw operation: Operate KY-116/U. c. Request a test transmission from other station so that adjustments in steps 7 through 11 can be properly performed.	a. Needle on audio level meter should move. Voice peaks should produce an indication of close to, but not over, 100 on the audio level meter (lower side). Sidetone should be heard in H-113/U. b. Sidetone should be heard in H-113/U. c. Test transmission from other station is heard in H-113/U.
6	R-392/URR ANT TRIM control ---	Adjust for maximum indication on CARRIER LEVEL meter or for desired listening level.	A maximum (peak) indication will be obtained on CARRIER LEVEL meter. Desired listening level is heard in H-113/U.
7	R-392/URR AF GAIN control -----	Adjust for desired listening level	Signal heard in H-113/U will be adjusted to desired listening level.
8	R-392/URR function switch -----	Set to LIMITER if objectionable noise is heard in H-113/U.	Noise level heard in H-113/U will decrease.
9	R-392/URR BAND WIDTH switch	Set to 4KC or, if necessary, to 2KC to eliminate interference caused by another signal.	Interfering signal will decrease in strength or will be eliminated completely.
10	R-392/URR function switch and RF GAIN SQUELCH THRESH control.	If noise heard in H-113/U is very annoying between transmissions, set function switch to SQ and turn RF GAIN SQUELCH THRESH control slowly counter-clockwise to point which minimizes noise. Do not set function switch to SQ if signal is weak or subject to fading, or for cw operation.	Noise level heard in H-113/U will decrease.

Step	Control or switch	Action	Indication
11	R-392/URR BFO PITCH control --	If a cw signal is being received, adjust for signal of pleasing pitch.	The pitch of the cw signal heard in the H-113/U will change.
12	T-195(*)/GRC-19 RELAY-NORMAL-DUPLEX switch.	Set to RELAY.	
13	T-195(*)/GRC-19 LINE LEVEL DBM control.	Adjust to produce an indication close to, but not over, 100 on the audio level meter. <i>Note: If the audio level meter cannot be made to indicate close to 100, perform steps 14 and 15 below.</i>	Audio level meter should indicate close to, but not over, 100.
14	R-392/URR AF GAIN control -----	Turn in clockwise direction -----	Level of audio signal heard in H-113/U will increase.
15	T-195(*)/GRC-19 LINE LEVEL DBM control.	Adjust to produce indication close to, but not over, 100 on the audio level meter.	Line level meter should indicate close to, but not over, 100.

24. Recognition and Identification of Jamming

Under real or simulated tactical conditions, it is possible for the R-392/URR to be jammed by the enemy. Jamming is easily done by transmission of a strong signal on the same frequency to which you are listening, which makes it difficult or impossible to hear the desired signal. Unusual noises or strong interference heard on the R-392/URR may be enemy jamming, signals from a friendly station, noise from a local source, or a defective R-392/URR. To determine whether the interference is originating in the R-392/URR, disconnect the antenna and short the center conductor of the ANT connector to the chassis. If the interference continues, the R-392/URR is defective.

25. Antijamming

When it is known that an R-392/URR is being jammed, the operator will notify the immediate superior officer immediately and continue to operate the equipment. To provide maximum intelligibility of jammed signals, follow the operational procedure below.

a. Set the BAND WIDTH switch to 2KC.

b. Detune the R-392/URR by turning the KILOCYCLES control several degrees on either side of the desired signal. Detuning may cause some separation of the desired signal and the jamming signal.

c. Adjust the ANT TRIM control. This adjustment may reduce the strength of the jamming signal.

d. If voice signals are being received, set the AGC switch to OFF. If cw signals are being received, the AGC switch is already set to OFF. Vary the RF GAIN SQUELCH THRESH control. Varying this control may reduce the jamming signal enough to permit the desired weaker signal to be heard.

e. If cw signals are being received, adjust the BFO PITCH control. This adjustment may reduce the jamming signal enough to permit the wanted signal to be heard.

f. If the above procedures do not provide sufficient signal separation for operation, proceed as follows:

- (1) If the AN/GRC-19 is installed in a vehicle, move the vehicle (if possible) to a new location.
- (2) If a doublet antenna (Antenna Group AN/GRA-14 or AN/GRA-50) is being used, change the location (if possible) of the antenna. If the jamming signal still does not permit operation, change to a whip antenna.
- (3) If a whip antenna is being used, change to a doublet antenna.
- (4) Change to an alternate frequency and alternate call sign.

26. Stopping Procedure

a. *Standby Condition.* When the AN/GRC-19 is not to be used for a short period of time, but is to be kept ready for immediate use, proceed as follows:

- (1) Set the T-195(*)/GRC-19 SERVICE SELECTOR switch to STAND BY.

(2) Set the R-392/URR function switch to STAND BY.

b. Stopping Equipment. Turn the AN/GRC-19 off as follows:

(1) Set the T-195(*)/GRC-19 SERVICE SELECTOR switch to OFF.

(2) Set the R-392/URR function switch to OFF.

CHAPTER 4

MAINTENANCE INSTRUCTIONS

27. Scope of Operator's Maintenance

The following is a list of maintenance duties normally performed by the operator of Radio Set AN/GRC-19. These procedures do not require special tools or test equipment.

- a. Preventive maintenance (para 28).
- b. Daily preventive maintenance checks and services (para 30).
- c. Cleaning (para 31).

28. Preventive Maintenance

Preventive maintenance is the systematic care, servicing, and inspection of equipment to prevent the occurrence of trouble, to reduce downtime, and to assure that the equipment is serviceable.

a. *Systematic Care.* The procedures given in paragraph 30 cover daily systematic care essential to proper upkeep and operation of equipment. The cleaning operations (para 31) should be performed once a day.

b. *Preventive Maintenance Checks and Services.* The preventive maintenance checks and services chart (para 30) outlines functions to be performed at specific intervals. These checks and services are designed to maintain Army equipment in a combat serviceable condition; that is in good general (physical) condition and in

good operating condition. To assist operators in maintaining combat serviceability, the charts indicate what to check, how to check, and what the normal conditions are; the *Reference* column lists the illustrations, paragraphs, or manuals that contain detailed repair or replacement procedures. If the defect cannot be remedied by the operator, higher echelon maintenance or repair is required. Records and reports of these checks and services must be made in accordance with TM 38-750.

29. Preventive Maintenance Checks and Services Periods

Preventive maintenance checks and services of the AN/GRC-19 are required on a daily basis. Paragraph 30 specifies preventive maintenance checks and services that must be accomplished daily and under special conditions listed below.

- a. Before the vehicle starts on a mission.
- b. When the equipment is initially installed.
- c. When the equipment is reinstalled after removal for any reason.
- d. At least once each week if the equipment is maintained in standby condition.

30. Daily Preventive Maintenance Checks and Services

Sequence No.	Item	Procedures	Reference
1	Completeness ---	Inspect the AN/GRC-19 for the presence of all units and accessory items.	Appx II
2	Installation -----	Inspect the AN/GRC-19 for proper installation -----	Chapter 2
3	Cables -----	Clean, check, and tighten the cable connections -----	Fig. 8
4	Exterior surfaces	Clean the exterior surfaces of the units comprising the AN/GRC-19.	Para 31
5	Air filter -----	Remove the air filter from the T-195(*)/GRC-19 and replace with clean filter. Clean removed filter.	Para 31 and 32
6	Controls and switches.	While making the operational checks (item 7) observe that the mechanical action of each switch and control is smooth and free of external or internal binding.	Para 22 and 23
7	Operational check	Start, calibrate, and tune the AN/GRC-19 -----	Para 22 and 23

31. Cleaning

Inspect the exterior surfaces of the units comprising the AN/GRC-19. The exterior surfaces should be clean, and free of dust, grease, and fungus.

a. Remove dust and dirt with a clean soft cloth.

Warning: Cleaning Compound (Federal stock No. 7930-395-9542) is flammable and its fumes are toxic. Provide adequate ventilation. Do not use near a flame.

b. Remove grease, fungus, and ground-in dirt from the exterior surfaces; use a cloth dampened (not wet) with cleaning compound.

c. Remove dust and dirt from the plugs and receptacles.

d. Clean the panels and control knobs; use a soft clean cloth. If necessary, dampen the cloth with mild soap and water.

e. Clean the canvas items with a brush or cloth that has been moistened with cleaning compound.

f. Clean the air filter as follows:

- (1) Wash the air filter in hot water with a strong soap solution.
- (2) Rinse the air filter with clear water and allow to air-dry.

- (3) Dip or spray the air filter with light oil.

Caution: Use only light oil and be sure all excess oil has been drained from the filter before using. Excess oil may damage the T-195(*)/GRC-19.

- (4) Drain the air filter for 24 hours.

Note: When cleaning Dust Filter MX-3492/GRC-19 (TM 11-5820-335-10, fig. 3) do not oil the filter.

32. Removal and Replacement of Air Filter (fig. 9)

The air filter is located in the air-intake port, under the air-intake cover on the T-195(*)/GRC-19. To remove the air filter, release the two catches on each side of the air-intake port and remove the air-intake cover. Grasp the handle on each side of the filter and pull the filter straight forward. Replace the filter with a clean one. Replace the air-intake cover and close the catches.

Note: For removal and replacement procedures for Dust Filter MX-3492/GRC-19, refer to TM 11-5820-335-10, para. 23.

CHAPTER 5

EQUIPMENT SERVICEABILITY CRITERIA

33. Purpose

The procedures described in paragraphs 36 through 38 will be used to evaluate equipment serviceability under the provisions of AR 750-10. This chapter does not affect the requirements in other portions of the technical manual pertaining to periodic preventive maintenance service on the equipment.

34. Scope of Equipment Serviceability Criteria

The instructions in this chapter apply to all organizations of the Army and will be performed by first or second echelon maintenance personnel. Evaluation of each assigned equipment will be made periodically in accordance with these instructions; the frequency of the evaluation will be directed by appropriate Commands.

35. Categories of Equipment Serviceability

a. Equipment will be rated as either *GO* (Combat Ready) or *NO-GO* (not Combat Ready).

b. The *GO* condition is subdivided into two categories: *GREEN* and *AMBER*.

(1) *GREEN* — *Completely Combat Ready*.

(a) Equipment passes all applicable tests in this chapter.

(b) All running spares and accessories are on hand at the using organization.

(2) *AMBER* — *Conditionally Combat Ready*. Equipment passes all applicable tests in this chapter. As soon as the complete prescribed load of running spares and accessories is on hand at the using organization, the category *AMBER* changes to *GREEN*.

c. The *NO-GO* classification is defined as category *RED*. Category *RED* is in effect when:

(1) Equipment fails one or more of the applicable tests in this chapter even though all running spares,

tools, and accessories are on hand at the using organization.

(2) One or more *URGENT* modification work orders (MWO) have not been applied.

36. Inspection and Maintenance Worksheet

a. DA Form 2404, Equipment Inspection and Maintenance Worksheet, will be used to record results of the equipment serviceability evaluation as follows:

(1) Complete blocks 1, 2, 3, and 5.

(2) Enter *ESE* (equipment serviceability evaluation) in block 6.

(3) Enter the publication number and publication date in block 7.

(4) Enter the item number of each test in column *a* and the symbol *P* (for Pass) or *F* (for Fail) as applicable in column *b*.

(5) Record the date of each evaluation below the last entry in column *b*.

(6) After performing the evaluation, the evaluator will sign above column *b*. Supervisor will sign after the last entry in column *b*.

b. Lines may be drawn vertically in columns *c* and *d* to record subsequent evaluations. If column *c* or *d* is used for recording subsequent evaluations, the date of evaluation will be recorded and DA Form 2404 will be signed by the evaluator and his supervisor.

37. Test Conditions

a. A monitor radio set is located within 50 miles of the AN/GRC-19 under test.

b. The monitor radio set and the AN/GRC-19 under test are assigned the same frequency.

c. Connect the H-113/U to the AUDIO connector on the R-392/URR.

d. Open the air exhaust and intake ports on the T-195(*)/GRC-19 so that the red decals will show.

e. Connect the M-29(*)/U to the AUDIO connector on the T-195(*)/GRC-19.

f. Set the switches and controls as follows:

- (1) R-392/URR.
 - (a) BFO switch to ON.
 - (b) AGC switch to ON.
 - (c) RF GAIN SQUELCH THRESH control maximum clockwise.
 - (d) AF GAIN control to midposition.
 - (e) DIAL LOCK control maximum counterclockwise.
 - (f) BAND WIDTH control to 8KC.
 - (g) DIAL ZERO control maximum counterclockwise.
 - (h) Function switch to STAND BY.

- (i) DIAL-DIM switch to ON.
- (j) BFO PITCH control to 0.
- (2) T-195(*)/GRC-19.
 - (a) DIAL-DIM switch to FULL.
 - (b) TUNING CONTROL and BAND SELECTOR locking bars fully clockwise.
 - (c) RELAY - NORMAL - DUPLEX switch to NORMAL.

38. Test Items

Follow the procedures below to test the equipment.

a. Preliminary starting.

Item	Action	Result
1-1. T-195(*)/GRC-19 SERVICE SELECTOR switch.	Set to STAND BY -----	Equipment blower is heard.
1-2. R-392/URR function switch-----	Set to NORMAL -----	Background noise is heard in H-113/U.
1-3. R-392/URR AGC switch-----	Set to CAL -----	CARRIER LEVEL meter moves to the right.

b. DIAL ZERO adjustment for Receiver, Radio R-392/URR with "turn" type DIAL ZERO control.

Item	Action	Result
2-1. R-392/URR MEGACYCLES and KILOCYCLES controls.	Tune to 100-kc frequency closest to assigned frequency.	Beat note is heard in vicinity of 100-kc point.
2-2. R-392/URR DIAL ZERO control.	Turn maximum clockwise-----	Dial is locked.
2-3. R-392/URR KILOCYCLES control.	Adjust KILOCYCLES control for zero beat indication.	Dial remains stationary; tone lost.
2-4. R-392/URR DIAL ZERO control.	Turn maximum counterclockwise ----	Dial is unlocked; permits KILOCYCLES control to move dial.

c. DIAL ZERO adjustment for Receiver, Radio R-392/URR with "push-in" type DIAL ZERO control.

Item	Action	Result
3-1. R-392/URR MEGACYCLES and KILOCYCLES controls.	Adjust until tone is heard at 100-kc point nearest operating frequency. Adjust kilocycles control for zero beat indication in H-113/U.	Tone will be heard in H-113/U; tone is lost.
3-2. R-392/URR DIAL LOCK control.	Turn fully clockwise.	KILOCYCLES control is locked.
3-3. R-392/URR DIAL ZERO control.	Push in; adjust until frequency indicated in frequency indicator ends in 00.	Frequency appears in frequency indicator ending in 00 indication.
3-4. R-392/URR DIAL LOCK control.	Turn maximum counterclockwise.	KILOCYCLES control is unlocked; permits KILOCYCLES control to move freely.

d. Tuning, transmitting, and receiving.

Item	Action	Result
4-1. R-392/URR AGC switch -----	Set to ON -----	CARRIER LEVEL meter needle moves to left and background noise is heard.
4-2. R-392/URR KILOCYCLES and DIAL LOCK controls.	Tune to assigned frequency and turn DIAL LOCK control maximum clockwise.	Dial indicates assigned frequency. KILOCYCLES control is locked.
4-3. T-195(*)/GRC-19 TEST METER switch.	Set to BATT -----	Test meter indicates within BATTERY scale shaded area. T-195(*)/GRC-19 tunes to frequency formerly preset at this position.
4-4. T-195(*)/GRC-19 PRESET CHANNELS switch.	Set to desired channel. Wait until TUNING CONTROL and BAND SELECTOR switch stop turning. <i>Note:</i> Reminder spring must be depressed before the PRESET CHANNELS switch can be turned.	
4-5. T-195(*)/GRC-19 BAND SELECTOR switch.	Unlock locking bar and adjust to assigned band and lock switch. Line up arrow with white line.	Assigned band indicated on BAND CHANNEL dial.
4-6. T-195(*)/GRC-19 SERVICE SELECTOR switch.	Set to CALIBRATE -----	Low voltage dynamotor (in some models) is heard starting. Background noise is lost.
4-7. TEST METER switch -----	Set to PA GRID -----	Test meter indicates within PA GRID scale shaded area.
4-8. TEST METER switch -----	Set to PA CATH -----	Test meter indicates approximately zero.
4-9. R-392/URR function switch -----	Set to NET -----	Background noise is heard in H-113/U.
4-10. T-195(*)/GRC-19 TUNING CONTROL.	Unlock locking bar and adjust for zero beat; lock TUNING CONTROL.	Zero beat indication is heard in H-113/U. The needle of CARRIER LEVEL meter of the R-392/URR moves to the right.
4-11. T-195(*)/GRC-19 DIAL ZERO control.	Adjust to assigned frequency ----	Desired operating frequency appears in frequency indicator.
4-12. T-195(*)/GRC-19 SERVICE SELECTOR switch.	Set to VOICE/FSK or CW -----	Background noise is heard in H-113/U.
4-13. R-392/URR function switch -----	Set to NORMAL -----	Background noise is heard in H-113/U.
4-14. T-195(*)/GRC-19 TEST KEY ---	Hold in ON position until test meter needle stops moving.	Meter indicates in PA CATHODE scale, shaded area. TUNING INDICATOR lamp is on steady.
4-15. R-392/URR BFO switch and M-29(*)/U.	Set receiver BFO switch to OFF and operate push-to-talk switch in M-29(*)/U. Request a voice test signal from monitor radio set.	Audio level meter of T-195(*)/GRC-19 indicates and sidetone signal is audible in H-113/U.
4-16. R-392/URR AF GAIN control -----	Adjust so that received test signal is at a comfortable level.	Loudness of test signal from monitor radio set heard in H-113/U. varies.

CHAPTER 6

MATERIAL USED IN CONJUNCTION WITH AN/GRC-19

39. Purpose of Additional Material

Although it is possible to operate the AN/GRC-19 locally, it may be necessary to install the AN/GRC-19 at one location and to control the operation from a more protected and remote location. The AN/GRC-19 may be operated from a remote site by use of Control Group AN/GRA-6 (para 40). Maximum distance from the AN/GRC-19 is 2 miles if a two-conductor line, such as Wire WD-1/TT, is used. Voice operation only from the remote site is possible.

40. Remote Control Operation (fig. 12)

Control Group AN/GRA-6 (fig. 11) may be used to operate the AN/GRC-19 from a remote location. Normal or duplex operation (para 12) is available for use. If nor-

mal operation is desired, set the T-195 (*)/GRC-19 NORMAL-DUPLEX-RELAY switch to NORMAL, and hook up the equipment as indicated in a through e below. For duplex operation, set the T-195 (*)/GRC-19 NORMAL-DUPLEX-RELAY switch to DUPLEX and hook up the equipment as indicated in a through j below.

Note: For duplex operation, one AN/GRA-6 is required for transmission, and one is required for reception. One antenna is required for the R-392/URR, and one is required for the T-195(*)/GRC-19.

a. Connect Cable Assembly, Special Purpose, Electrical CX-1599/U (part of Local Control C-434/GRC) to the R-392/URR AUDIO connector.

b. Connect the H-33/PT to the AUDIO connector on the C-434/GRC.

c. Connect field wire (maximum distance 2 miles), such as Wire WD-1/TT, between LINE L1 and L2 binding posts on

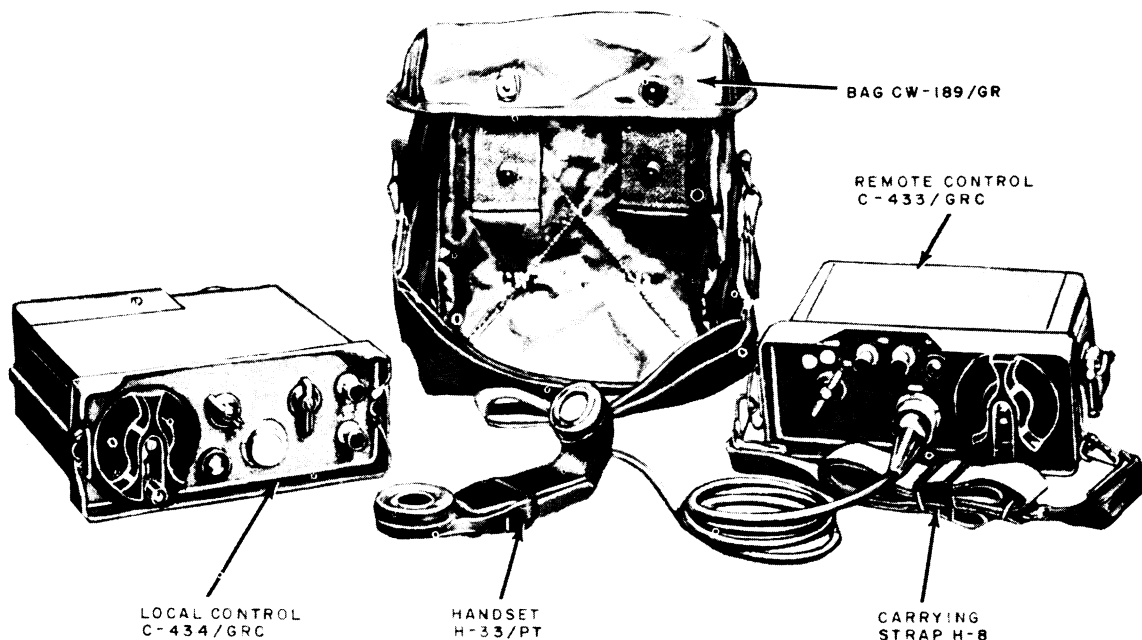

TM5820-295-10-34

Figure 11. Control Group AN/GRA-6.

the C-434/GRC and the LINE L1 and L2 binding posts on Remote Control C-433/GRC.

d. Connect Handset H-33/PT to the AUDIO connector on the C-433/GRC.

e. Set the T-195(*)/GRC-19 SERVICE SELECTOR switch to REMOTE.

f. Connect Cable Assembly, Special Purpose, Electrical CX-1599/U from the second Local Control C-434/GRC to the T-195(*)/GRC-19 AUDIO connector.

g. Connect field wire, such as Wire WD-1/TT, between LINE L1 and L2 binding posts on the second C-434/GRC and the LINE L1 and L2 binding posts on Remote Control C-433/GRC.

h. Disconnect Cable Assembly, Radio Frequency CG-1127/U from between the T-195(*)/GRC-19 RECEIVER ANTENNA and the R-392/URR ANT connector.

i. Connect one antenna to the T-195(*)/GRC-19 WHIP ANTENNA binding post and

one antenna to the R-392/URR ANT connector.

j. Connect Handset H-33/PT to the AUDIO connector on the second C-433/GRC.

k. The AN/GRA-6 connected to the R-392/URR is used for reception, and the AN/GRA-6 connected to the T-195(*)/GRC-19 is used for transmission.

l. For operation of Control Group AN/GRA-6 refer to TM 11-5038.

41. Antenna Groups to Extend Communication Range

Antenna Group AN/GRA-4 (fig. 13) or AN/GRA-50 may be used with the AN/GRC-19 to extend its communication range. For detailed instructions concerning the AN/GRA-4, refer to TM 11-2651, and for the AN/GRA-50, refer to TM 11-5820-467-15.

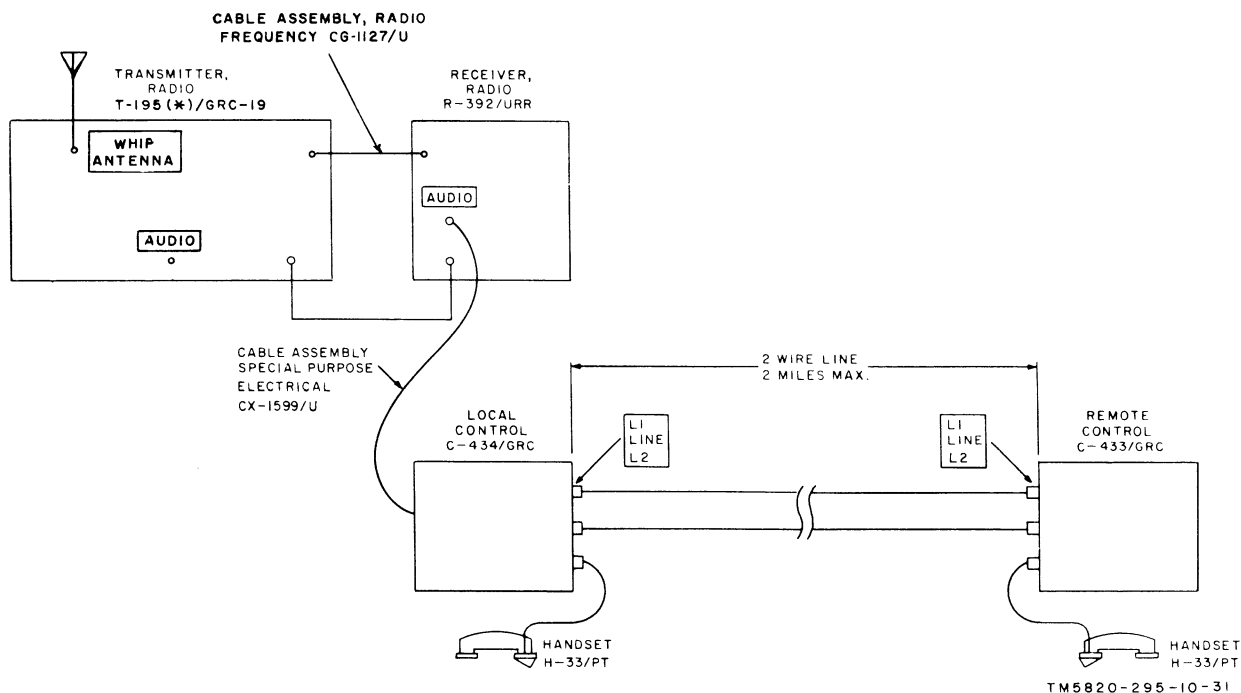
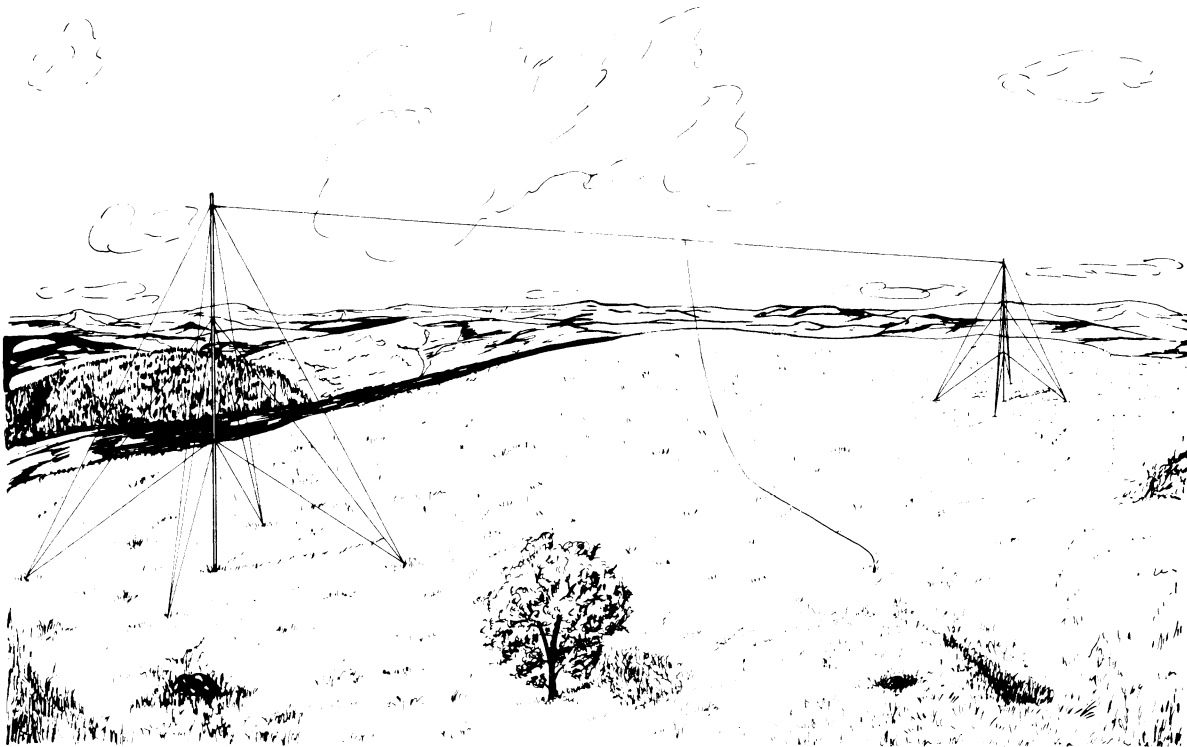

Figure 12. Control Group AN/GRA-6 connected for remote normal operation of Radio Set AN/GRC-19, simplified block diagram.



TM5820-295-10-24

Figure 13. Antenna Group AN/GRA-4.

CHAPTER 7

DEMOLITION OF MATERIAL TO PREVENT ENEMY USE

42. Authority for Demolition

Demolition of the equipment will be accomplished only upon the order of the commander. The destruction procedure outlined in paragraph 43 will be used to prevent further use of the equipment.

43. Methods of Destruction

Any or all methods of destruction given below may be used. The time available will be the major determining factor for the method used. The tactical situation also will determine how the destruction order will be carried out.

a. Smash. Smash the interior of the set; use sledges, axes, hammers, crowbars, and any other heavy tools available. Smash the tuning indicator, dials, meter connectors, and controls with the heaviest tool on hand if time does not permit removing the set from the case.

b. Cut. Cut cabling, cording, and wiring; use axes, machetes, and similar tools. Cut all cords and cables in a number of places. If time permits, slash the interior wiring and cabling.

Warning: Be extremely careful with explosives and incendiary devices. Use these items only when the need is urgent.

c. Burn. Burn instruction literature first. Burn as much of the equipment as is

flammable; use gasoline, oil, flamethrower, or similar tools. Pour gasoline on the cut cables and internal wiring and ignite it. Use a flamethrower to burn the spare parts or pour gasoline on the spares and ignite them. Use incendiary grenades to complete the destruction of the equipment interiors.

d. Explode. Use explosives to complete demolition or to cause maximum destruction when time does not permit complete demolition by other means. Powder charges, fragmentation grenades, or incendiary grenades may be used. Place the explosive charge against the frequency indicators to cause maximum destruction; the second most effective location is against the T-195(*)/GRC-19 TEST KEY switch. Incendiary grenades usually are most effective for destruction of small parts and wiring.

e. Dispose. Bury or scatter the destroyed parts in slit trenches, foxholes, or throw them into streams.

44. Handling, Storage, and Disposal of Radioactive Material

Follow the procedures for safe handling, storage, and disposal of radioactive materials as directed by TB SIG 225, AR 40-580, and AR 755-380.

APPENDIX I

REFERENCES

Following is a list of applicable references available to the operator of Radio Set AN/GRC-19.

AR 40-580	Control of Hazards to Health from Radioactive Materials.
AR 750-10	Maintenance of Supplies and Equipment Materiel Readiness (Serviceability of Unit Equipment).
AR 755-380	Disposal of Unwanted Radioactive Material.
DA Pam 310-4	Index of Technical Manuals, Technical Bulletins, Supply Bulletins, Lubrication Orders, and Modification Work Orders.
TB SIG 225	Radioactive Electron Tube Handling.
TM 11-2651	Antenna Group AN/GRA-4.
TM 11-5038	Control Group AN/GRA-6.
TM 11-5820-334-10	Operator's Manual, Radio Receiver R-392/URR.
TM 11-5820-335-10	Operator's Manual: Transmitter, Radio T-195/GRC-19, T-195A/GRC-19, and T-195B/GRC-19.
TM 11-5820-467-15	Operator, Organizational, Field, and Depot Maintenance Manual: Antenna Group AN/GRA-50.
TM 38-750	The Army Equipment Record System and Procedures.

APPENDIX II

BASIC ISSUE ITEMS LIST

Section I. INTRODUCTION

1. General

This appendix lists items supplied for initial operation and for running spares. The list includes tools, accessories, parts, and material issued as part of the major end item. This portion includes all items authorized for basic operator maintenance of the equipment. End items of equipment are issued on the basis of allowances prescribed in equipment authorization tables and other documents that are a basis for requisitioning.

2. Columns

- a. *Source, Maintenance, and Recoverability Code.* Not used.
- b. *Federal Stock Number.* This column lists the 11-digit Federal stock number.
- c. *Designation by Model.* Not used.
- d. *Description.* Nomenclature or the

standard item name and brief identifying data for each item are listed in this column.

e. *Unit of Issue.* The unit of issue unless otherwise indicated is the supply term by which the individual item is counted for procurement, storage, requisitioning, allowances, and issue purposes.

f. *Expendability.* Nonexpendable items are indicated by NX. Expendable items are not annotated.

g. *Quantity Authorized.* Under "Items Comprising an Operable Equipment," the column lists the quantity of items supplied for the initial operation of the equipment. Under "Running Spares and Accessory Items," the quantities listed are those issued initially with the equipment as spare parts. The quantities are authorized to be kept on hand by the operator for maintenance of the equipment.

Section II. FUNCTIONAL PARTS LIST

(1) Source, maintenance, and recoverability code	(2) Federal stock number	(3) Designation by model	(4) Description	(5) Unit of issue	(6) Expendability	(7) Quantity authorized
	5820-030-0155		RADIO SET AN/GRC-19: A1-A3- 100w; nom output; receiver 0.5-32 mc, 32 bands; transmitter 1.5 to 20 mc, 10 bands; 28.5 v 30 amp for xmtr; 3.5 amp for receiver		NX	
			ITEMS COMPRISING AN OPERABLE EQUIPMENT			
	Ord thru AGC		TECHNICAL MANUAL 11-5820-295-10			2
	5820-571-1828		ANTENNA, SHEATH CLAMP: brass, 5/8 in. h x 1-1/3 in. lg o/a; 0.403; in. ID; Collins Radio Co part/dwg 542 3032 002			1
	5820-497-9644		BAG CW-206/GR; 41-1/2 in. lg x 26 in. w o/a			1
	5820-503-2953		BASE, MAST MP-65-B; Sig dwg SC-D-20718		NX	1

(1)				(2)	(3)				(4)	(5)	(6)	(7)
Source, maintenance, and recoverability code				Federal stock number	Designation by model				Description	Unit of issue	Expendability	Quantity authorized
				5995-272-9102					CABLE ASSEMBLY, RADIO FREQUENCY CG-1127/U: Sig dwg SC-C-25034			1
				5995-349-4844					CABLE ASSEMBLY, POWER, ELECTRICAL CX-2583/U: 6 ft 6 in. lg o/a; 2 stranded 18 AWG; cable type CO-02LGF (2/18)0250			2
				5995-280-3069					CABLE ASSEMBLY, SPECIAL PURPOSE, ELECTRICAL CX-1599/U: 10 in. lg o/a; MIL-C-3432; cable type CO-08AGF(2/14-6120) SJO-475; Sig Corps dwg SC-DL-25035			1
				5820-571-2558					COVER, ANTENNA: 46-3/4 in. lg x 1-3/4 in. max dia; Colvin-Friedman part CF-62B			1
				5995-280-3064					HEADSET CORD CX-1334/U: 39-1/2 in. lg; Sig dwg SG-C-68573			2
				5965-504-6370					HEADSET, ELECTRICAL H-113/U: 600 ohms impedance; Sig dwg SM-D-105212		NX	1
				5970-197-3576					INSULATOR IN-86: 4-3/8 in. lg x 3/4 in. dia o/a; Sig dwg SC-D-1134			1
				5805-503-3395					KEY, TELEGRAPH KY-116/U: manual actuation, 2 way lever adj; 5-1/4 in. lg x 4 in. w x 5 in. h o/a; Sig Corp DL-45824A		NX	1
				5820-199-8831					MAST SECTION MS-116-A: steel; 39-1/2 in. lg x 0.393 in. dia; SC-DL-100588			3
				5820-199-8843					MAST SECTION MS-117-A: steel; 39-1/2 in. lg x 0.373 in. dia; SC-DL-100588			1
				5820-199-8841					MAST SECTION MS-118-A: steel; 39-1/2 in. lg x 0.246 in. dia; SC-DL-100588			1
				5965-194-9770					MICROPHONE, M-29/U, M-29A/U: 40 to 100 ohms impedance; Sig dwg SM-D-96086		NX	1
				5820-396-3196					MOUNTING MT-851/GRC-19: SC-DL-145050		NX	1
				5820-503-1250					RECEIVER, RADIO R-392/URR: A1 and A3 type; 0.5 to 32 mc freq; 32 bands; 24 v dc; Sig dwg SM-D-144501		NX	1
				4020-240-2145					ROPE RP-5: (authorized allowances will be a minimum of, or a multiple of, 25 ft)	ft	NX	1
				5820-503-3428					TRANSMITTER, RADIO T-195/GRC-19, T-195A, T-195B/GRC-19: A1 and A3 type; 100 w max output; 1.5 to 20 mc freq; 10 bands, 8 channels; 28.5 dc; Sig dwg SM-C-143281		NX	1

(1)				(2)				(3)				(4)				(5)	(6)	(7)		
Source, maintenance, and recoverability code				Federal stock number				Designation by model				Description				Unit of issue	Expendability	Quantity authorized		
				6145-160-5114										WIRE, ELECTRICAL: ins stranded No. 14 AWG; MIL type W-128; (authorized allowance will be a minimum of or a multiple of 6 ft)				ft		6
														RUNNING SPARES AND ACCESSORY ITEMS						
				5965-504-6370										HEADSET, ELECTRICAL H-113/U: 600 ohms impedance; Sig dwg SM-D-105212					NX	1
				5970-197-3576										INSULATOR IN-86: 4-3/8 in. lg x 3/4 in. dia; Sig dwg SC-D-1134						1
				5805-503-3395										KEY, TELEGRAPH KY-116/U: manual actuation; 2 way lever adj; 5-1/4 in. lg x 4 in. 2 x 5 in. h o/a; Sig SC-DL-45824A					NX	1
				5820-199-8831										MAST SECTION MS-116-A: steel; 39-1/2 in. lg x 0.393 in. dia SC-DL-100588						2
				5820-199-8843										MAST SECTION MS-117-A: steel; 39-1/2 in. lg x 0.373 in. dia SC-DL-100588						1
				5820-199-8841										MAST SECTION MS-118-A: steel; 39-1/2 in. lg x 0.246 in. dia SC-DL-100588						1
				5965-194-9770										MICROPHONE M-29/U, M-29A/U; 40 to 100 ohms impedance; Sig dwg SM-D-96086					NX	1

By Order of Secretary of the Army:

EARLE G. WHEELER,
General, United States Army,
Chief of Staff.

Official:

J. C. LAMBERT,
Major General, United States Army,
The Adjutant General.

Distribution:

Active Army:

DASA (6)	Army Pic Cen (2)
USASA (2)	USA Mbl Spt Cen (1)
CNGB (1)	USA Elct Mat Agcy (25)
CofEngrs (1)	Chicago Proc Dist (1)
TSG (1)	USARCARIB Sig Agcy (1)
CSigO (5)	Sig Fld Maint Shop (3)
CofT (1)	C/Spt Svcs (1)
USA CD Agcy (1)	Units org under fol TOE:
USCONARC (5)	Two copies each:
USAMC (5)	1-7
ARADCOM (2)	1-17
ARADCOM Rgn (2)	1-25
OS Maj Comd (3)	1-26
OS Base Comd (2)	1-37
LOGCOMD (2)	1-57
USAECOM (5)	1-67
USAMICOM (3)	1-107
USASCC (4)	1-127
MDW (1)	1-137
Armies (2)	5-5
Corps (2)	5-6
USA Corps (3)	5-7
USATC AD (2)	5-8
USATC Engr (2)	5-15
USATC Inf (2)	5-16
USATC Armor (2)	5-17
Instls (2) except	5-25
Ft Monmouth (63)	5-26
Svc College (2)	5-27
Br Svc Sch (2)	5-35
GENDEP (OS) (2)	5-36
Sig Dep (OS) (12)	5-37
Sig Sec, GENDEP (5)	5-45
Army Dep (2) except	5-46
Ft Worth (8)	5-47
Lexington (12)	5-49
Sacramento (28)	5-52
Tobyhanna (12)	5-54
USA Elct RD Actv, White Sands (13)	5-77
USA Elct RD Actv, Ft Huachuca (2)	5-78
USA Trans Tml Comd (1)	5-112
Army Tml (1)	5-115
POE (1)	5-116
USAOSA (1)	5-117
AMS (1)	5-118
WRAMC (1)	5-129
AFIP (1)	5-145

5-146	7	11-96	32-56
5-147	7-11	11-97	32-57
5-148	7-12	11-98	32-67
5-155	7-15	11-117	37
5-156	7-16	11-155	37-42
5-157	7-25	11-157	39-51
5-167	7-26	11-165	39-52
5-225	7-35	11-167	39-65
5-226	7-36	11-237	44-2
5-237	7-42	11-500 (AA-AE, RM-RT)	44-12
5-278	7-45		44-15
5-376	7-46	11-555	44-16
6-37	8-15	11-557	44-85
6-100	8-16	11-587	44-87
6-101	8-35	11-592	44-235
6-125	8-36	11-597	44-236
6-126	8-61	17	44-435
6-135	8-75	17-22	44-436
6-136	8-76	17-25	44-437
6-200	8-77	17-26	44-445
6-201	8-78	17-35	44-446
6-225	9-9	17-36	44-447
6-226	9-12	17-42	44-448
6-300	9-47	17-45	44-535
6-301	9-76	17-46	44-536
6-302	9-87	17-51	44-537
6-315	9-167	17-52	44-544
6-316	9-217	17-55	44-545
6-317	9-227	17-56	44-546
6-319	9-377	17-57	55-547
6-325	9-500 (AA-AC)	17-65	55-548
6-326	10-201	17-66	55-11
6-327	11-5	17-85	55-12
6-330	11-6	17-86	55-38
6-401	11-7	17-105	55-157
6-501	11-15	17-106	55-457
6-525	11-16	17-107	55-468
6-545	11-37	17-108	44-469
6-565	11-38	17-408	55-500 (AA-AE)
6-575	11-55	29-1	57
6-576	11-57	29-21	57-5
6-577	11-95	29-56	57-42

NG: State AG (3); Units—Same as Active Army except allowance is one copy each unit.
 USAR: None.

For explanation of abbreviations used, see AR 320-50.

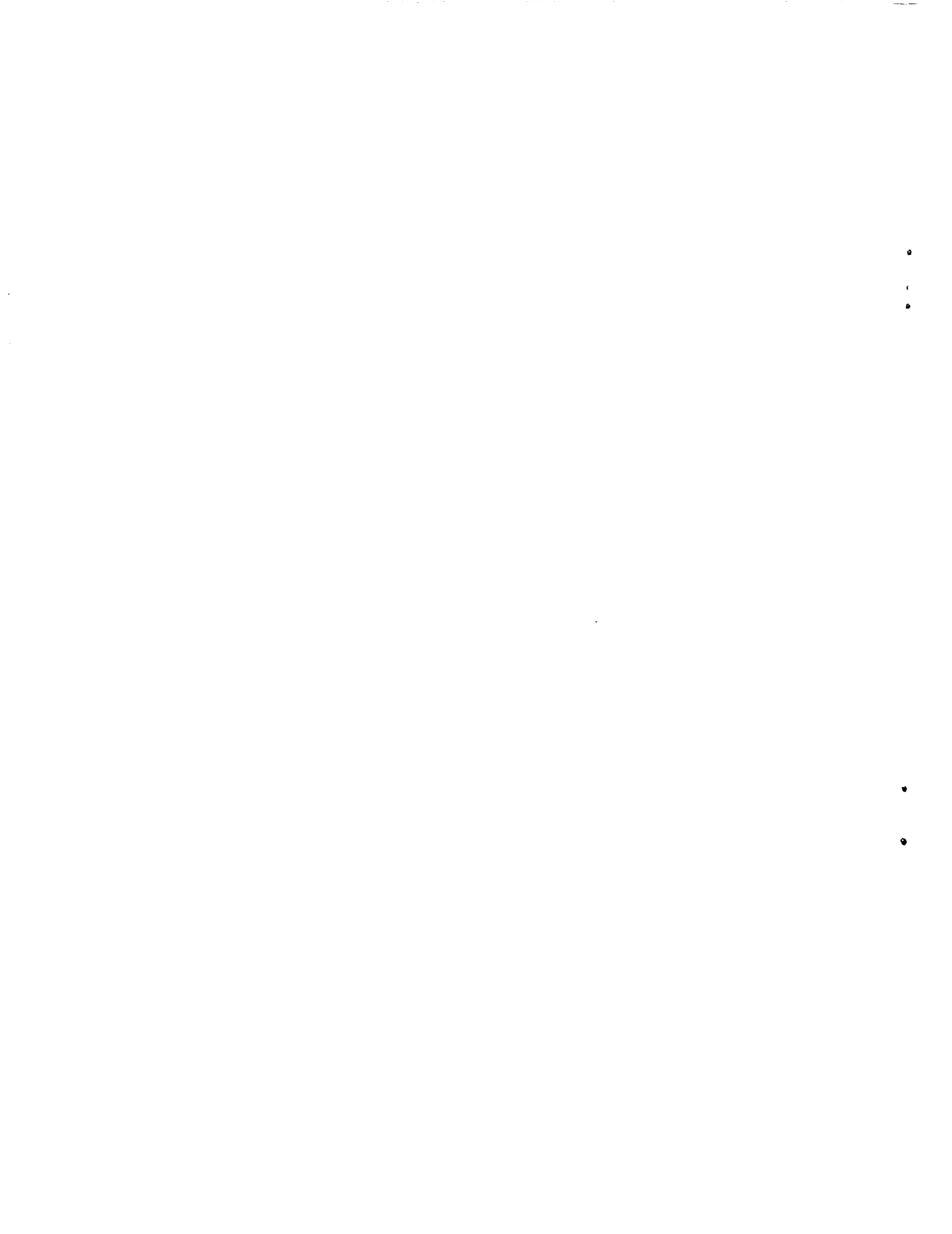

9
.
6

6
r
6

•

1

•

•

1

•

TM 11-5820-295-10 RADIO SET AN/GRC-19 -- 1963